

QUALSERV[®]

SOLUTIONS / INTERNATIONAL





Engineered to chill.
Built to perform.

As a division of Middleby Corporation—a world leader in developing advanced innovation and solutions for commercial and industrial foodservice—QualServ is proud to expand our commercial refrigeration offering. Our suite of commercial refrigeration and appliances is built around food safety and product preservation, designed to support the needs of modern foodservice operations across hospitality, foodservice, entertainment venues, and more. From chef bases and prep tables to reach-in refrigeration, our robust kitchen solutions are engineered to help operators prep and serve with confidence—trusted since 1978.



qualservintl.com

Inquiries: contactus@qualservintl.com

CONTENTS

REFRIGERATION SOLUTIONS

- 6 Mega-Tops
- 13 Sandwich Prep Tables
- 22 Pass-Thru Refrigerators
- 27 Pizza Prep Tables
- 37 Reach-In Refrigerators & Freezers
- 58 Refrigerator & Freezer Bases
- 63 Roll-In Refrigerators & Freezers
- 68 Roll-Through Refrigerators
- 71 Undercounter Front-Venting Refrigerators & Freezers
- 80 Undercounter Side-Mount Refrigerators & Freezers
- 85 Meat Curing Aging Cabinet
- 88 Mobile Refrigerated Cabinet
- 91 Proofer Retarder Combination





REFRIGERATION SOLUTIONS



Mega-Tops

REFRIGERATION SOLUTIONS

A staple in foodservice kitchens, mega-tops offer advantages that make them true assets to culinary operations. These spacious and versatile refrigerated prep tables are specifically designed to accommodate a wide range of ingredients, condiments, and toppings, providing chefs and kitchen staff with convenient access to essential ingredients during meal preparation. With multiple compartments and lower refrigeration compartments, mega-tops allow for the organization and storage of ingredients, optimizing workflow and reducing prep time. Constructed from high-quality materials and featuring robust refrigeration systems, QualServ mega-tops maintain consistent temperature control, preserving the freshness and quality of ingredients for extended periods. Designed for easy cleaning and maintenance, with removable compartments and stainless steel surfaces that are resistant to stains and corrosion. With their combination of practical functionality, durability, and reliability, QualServ mega-tops prove to be perfect additions to any foodservice kitchen, improving food preparation processes.

Refrigerated Mega Tops

- Mega Tops offer an all-in-one design solution for salad, sandwich and meal prep.
- Our trusted Mega Tops give staff the confidence of keeping ingredients fresh.
- Casters (2 locking) included for easy mobility.
- Features a full-length white polythene cutting board that provides a dedicated space to prep ingredients.



UCMT127-SS11A



UCMT132-SS11A



UCMT148-SS61A



UCMT160-SS61A

Model	Description	Voltage/Hz/Phase/Amps	Shipping Weight
UCMT127-SS11A	27" Refrigerated Mega Top (1 Door)	115v / 60hz / 1 / 3.4	242 lb
UCMT132-SS11A	32" Refrigerated Mega Top (1 Door)	115v / 60hz / 1 / 3.4	264 lb
UCMT148-SS61A	48" Refrigerated Mega Top (2 Doors)	115v / 60hz / 1 / 3.4	375 lb
UCMT160-SS61A	60" Refrigerated Mega Top (2 Doors)	115v / 60hz / 1 / 3.4	462 lb

Specifications

UCMT127-SS11A: 27 1/2" W X 35 1/2" D X 42 1/2" H
UCMT132-SS11A: 32 1/2" W X 35 1/2" D X 42 1/2" H
UCMT148-SS61A: 48" W X 35 1/2" D X 42 1/2" H
UCMT160-SS61A: 60 1/2" W X 35 1/2" D X 42 1/2" H
UCMT127-SS11A: 1 PVC coated wire shelf (included with purchase) holds (1) 12" x 20" pan and (3) 1/6 pans, pan rail holds (12) 1/6 pans
UCMT132-SS11A: 1 PVC coated wire shelf (included with purchase) holds (2) 12" x 20" pans, pan rail holds (12) 1/6 pans
UCMT148-SS61A: 2 PVC coated wire shelves (included with purchase) each hold (1) 12" x 20" pan and (3) 1/9 pans, pan rail holds (18) 1/6 pans
UCMT160-SS61A: 2 PVC coated wire shelves (included with purchase) each hold (1) 12" x 20" pan, (3) 1/6 pans and (3) 1/9 pans, pan rail holds (24) 1/6 pans
AISI 304 stainless steel interior and exterior
Autodefrost
CFC-free high-density polyurethane insulated cabinet
Electronic digital temperature control with alarms
Environmentally friendly R290 refrigerant
Factory pre-wired for dedicated outlet, 10 ft cord and plug included NEMA 5-15P
High efficiency compressor, side mount
High efficiency evaporator coil & condenser
NSF/ANSI Standard 7 compliant
Pan rail accommodates either 4" or 6" tall pans
Self-lubricating, sealed cast iron evaporator fan motor with high volume airflow design
Temperature range: 28°F to 46°F

Front (UCMT127-SS11A)

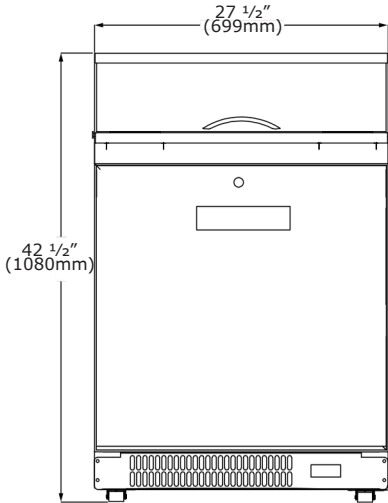

Front (UCMT132-SS11A)

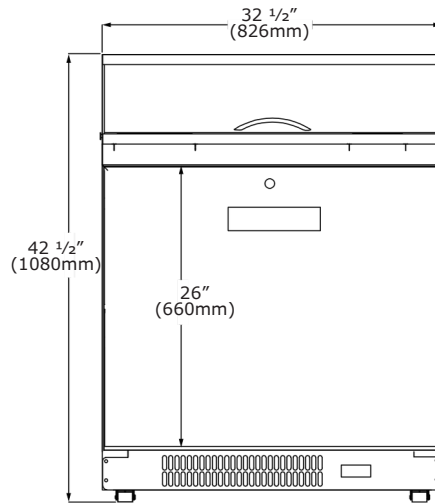

Side (All Models)

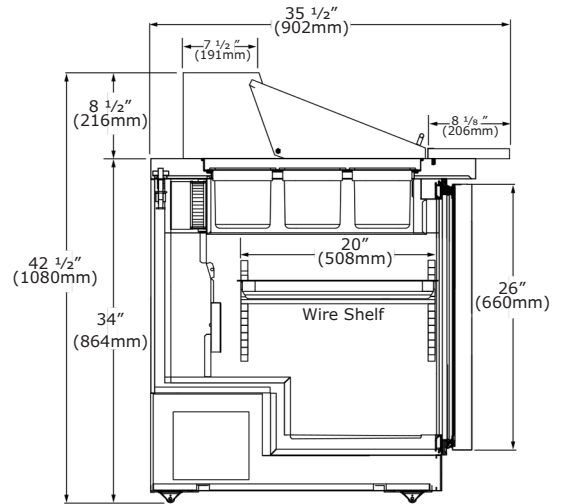

Top Rail (UCMT127-SS11A)

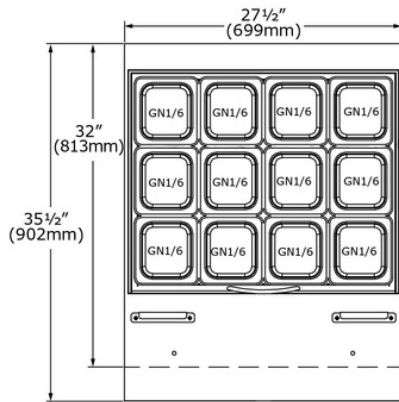

Top Rail (UCMT132-SS11A)

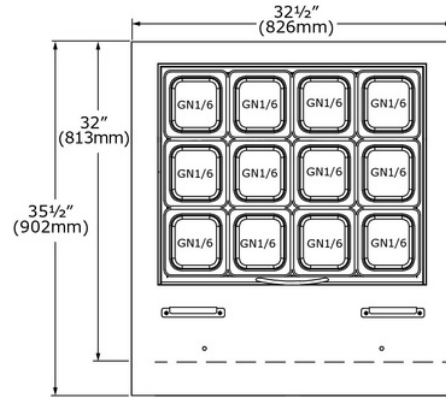

Door Interior (UCMT127-SS11A)

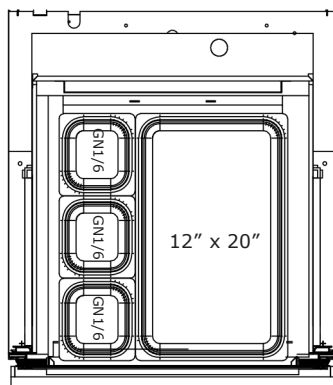

Door Interior (UCMT132-SS11A)

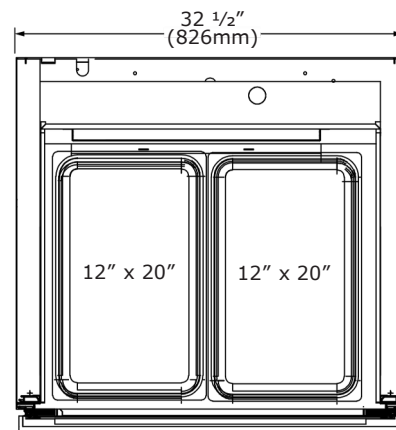

Front (UCMT148-SS61A)

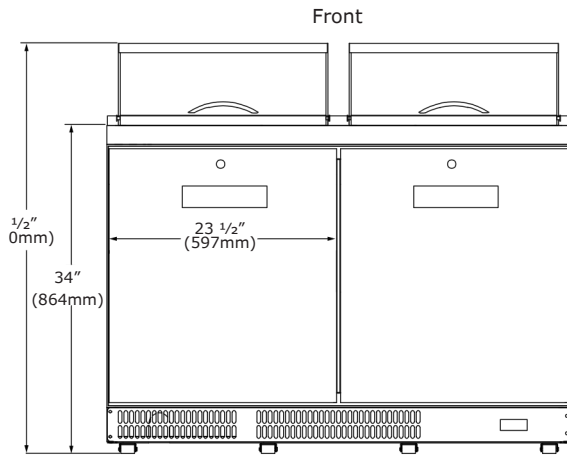

Front (UCMT160-SS61A)

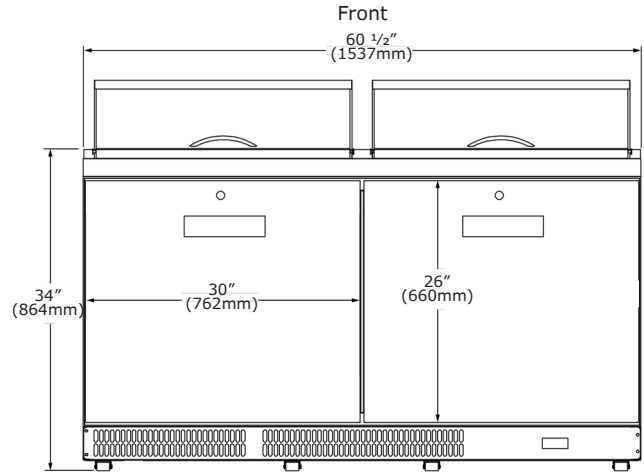

Top Rail (UCMT148-SS61A)

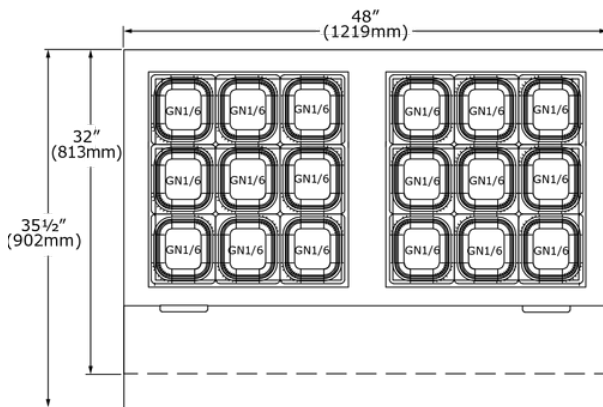

Top Rail (UCMT160-SS61A)

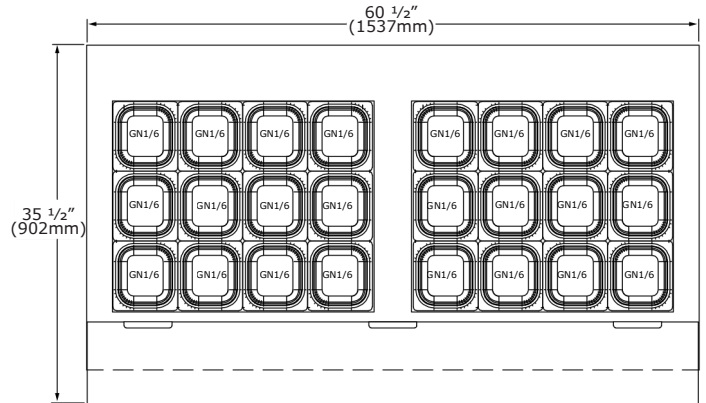

Door Interior (UCMT148-SS61A)

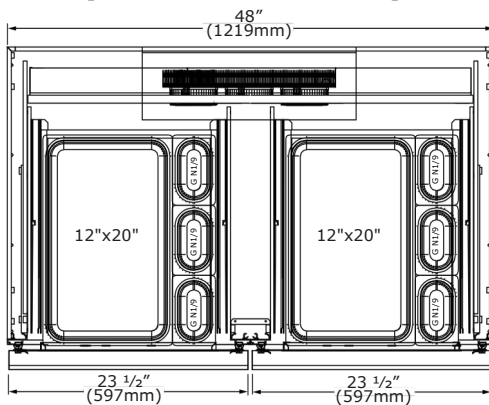

Door Interior (UCMT160-SS61A)

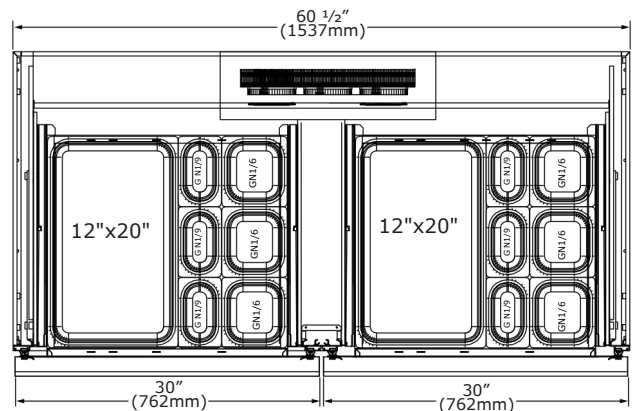

Commercial Warranty

3 Year (parts & labor) / 5 year sealed system (parts)
See complete warranty for details



Refrigerated Mega Tops with Drawers

- Mega Tops offer an all-in-one design solution for salad, sandwich and meal prep.
- Our trusted Mega Tops give staff the confidence of keeping ingredients fresh.
- Casters (2 locking) included for easy mobility.
- Features a full-length white polythene cutting board that provides a dedicated space to prep ingredients.



UCMT127-SS91A



UCMT132-SS91A



UCMT148-SS91A



UCMT160-SS91A

Model	Description	Voltage/Hz/Phase/Amps	Shipping Weight
UCMT127-SS91A	27" Refrigerated Mega Top (2 Drawers)	115v / 60hz / 1 / 3.4	264 lb
UCMT132-SS91A	32" Refrigerated Mega Top (2 Drawers)	115v / 60hz / 1 / 3.4	286 lb
UCMT148-SS91A	48" Refrigerated Mega Top (4 Drawers)	115v / 60hz / 1 / 3.4	408 lb
UCMT160-SS91A	60" Refrigerated Mega Top (4 Drawers)	115v / 60hz / 1 / 3.4	507 lb

Specifications

UCMT127-SS91A: 27 1/2" W X 35 1/2" D X 42 1/2" H
UCMT132-SS91A: 32 1/2" W X 35 1/2" D X 42 1/2" H
UCMT148-SS91A: 48" W X 35 1/2" D X 42 1/2" H
UCMT160-SS91A: 60 1/2" W X 35 1/2" D X 42 1/2" H
UCMT127-SS91A: Each drawer holds (1) 12" x 20" pan and (3) 1/6 pans, pan rail holds (12) 1/6 pans
UCMT132-SS91A: Each drawer holds (2) 12"x 20" pans, pan rail holds (12) 1/6 pans
UCMT148-SS91A: Each drawer holds (1) 12" x 20" pan and (3) 1/9 pans, pan rail holds (18) 1/6 pans
UCMT160-SS91A: Each drawer holds (1) 12" x 20" pan, (3) 1/6 pans and (3) 1/9 pans, pan rail holds (24) 1/6 pans AISI 304
stainless steel interior and exterior Auto defrost
Bottom drawer accommodates 4" tall pans
CFC-free high-density polyurethane insulated cabinet
Electronic digital temperature control with alarms
Environmentally friendly R290 refrigerant
Factory pre-wired for dedicated outlet, 10 ft cord and plug included NEMA 5-15P
High efficiency compressor, side mount
High efficiency evaporator coil & condenser
NSF/ANSI Standard 7 compliant
Pan rail accommodates either 4" or 6" tall pans
Self-lubricating, sealed cast iron evaporator fan motor with high volume airflow design
Temperature range: 28°F to 46°F
Top drawer accommodates 6" tall pans

Front (UCMT127-SS91A)

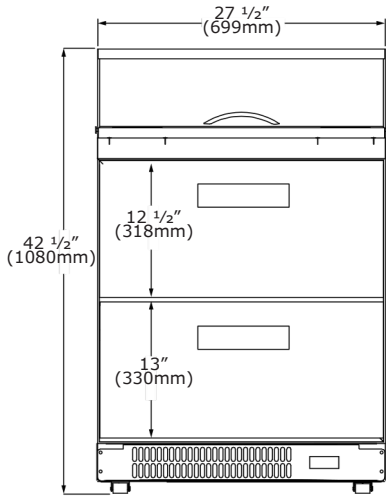

Front (UCMT132-SS91A)

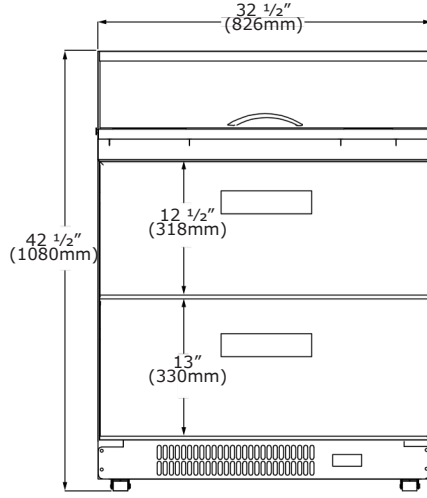

Side (All Models)

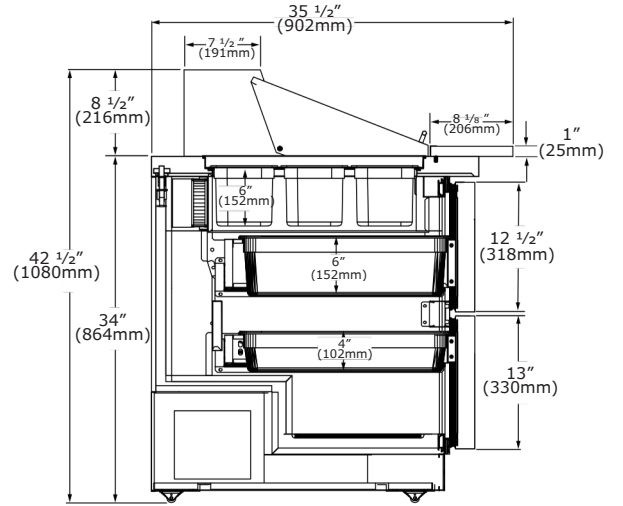

Top Rail (UCMT127-SS91A)

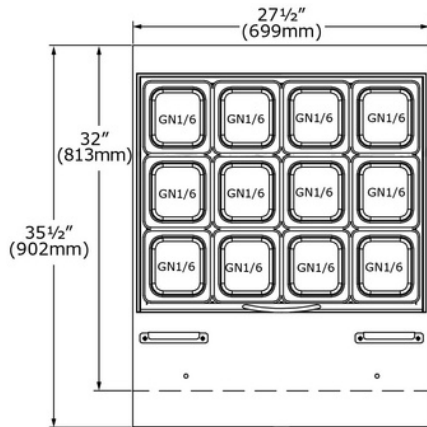

Top Rail (UCMT132-SS91A)

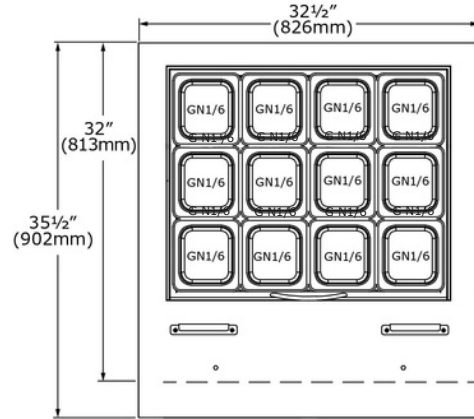

Drawer Interior (UCMT127-SS91A)

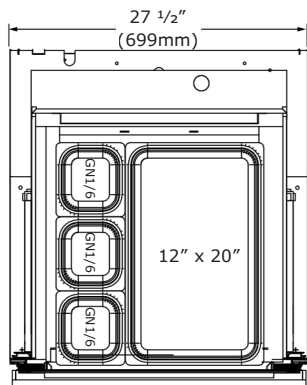

Drawer Interior (UCMT132-SS91A)

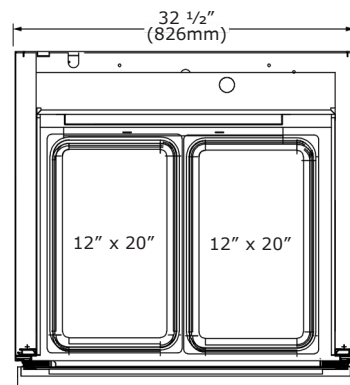

Front (UCMT148-SS91A)

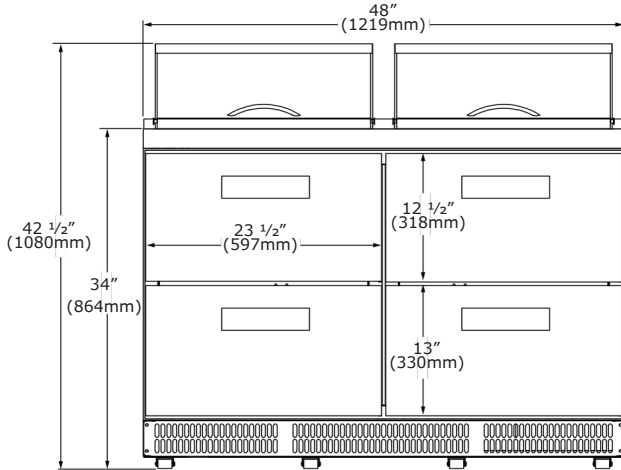

Front (UCMT160-SS91A)

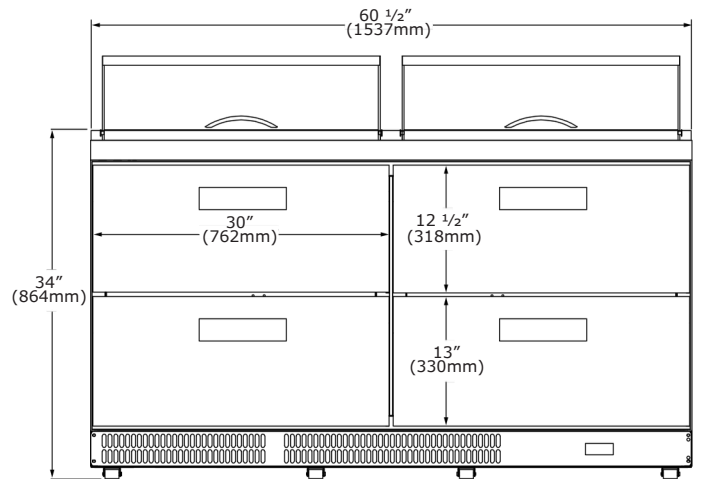

Top Rail (UCMT148-SS91A)

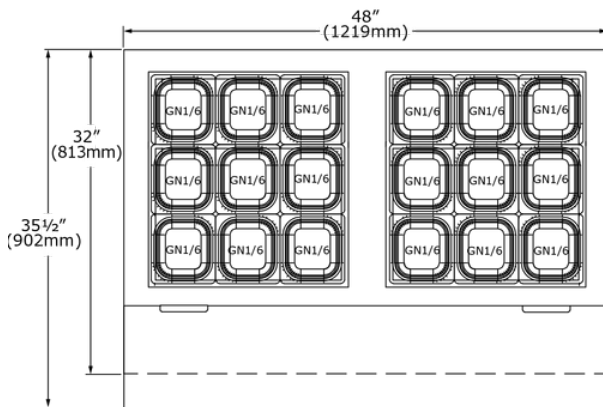

Top Rail (UCMT160-SS91A)

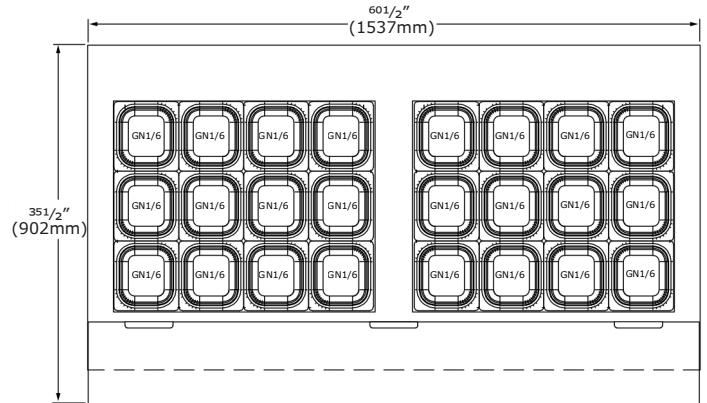

Drawer Interior (UCMT148-SS91A)

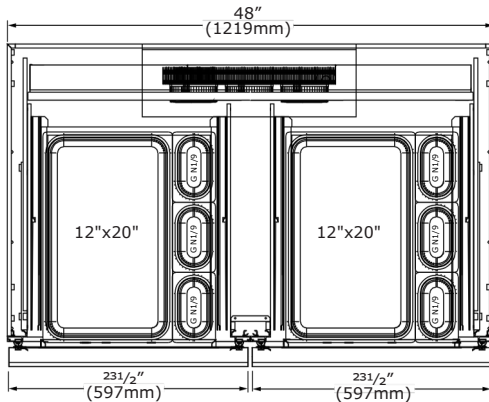

Drawer Interior (UCMT160-SS91A)

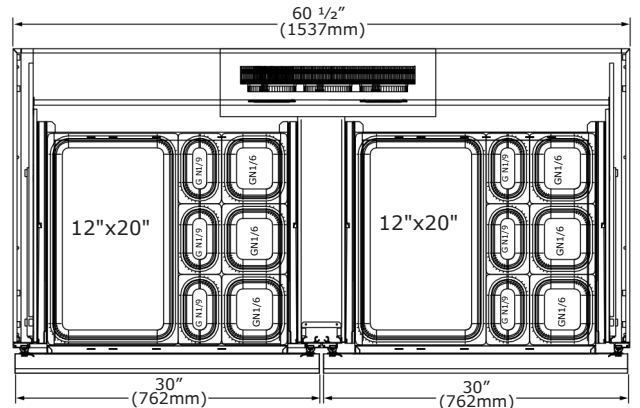

Commercial Warranty

3 Year (parts & labor) / 5 year sealed system (parts)
See complete warranty for details





Sandwich Prep Tables

REFRIGERATION SOLUTIONS

Refrigerated sandwich prep tables are a vital component in foodservice kitchens, offering significant benefits that make them invaluable to culinary operations. These roomy and adaptable refrigerated prep tables are crafted to hold a diverse array of ingredients, condiments, and toppings, giving chefs and kitchen staff easy access to essential items during meal preparation. Featuring multiple compartments and lower refrigeration sections, mega-tops facilitate the organization and storage of ingredients, enhancing workflow efficiency and minimizing preparation time.

With models featuring sealed condiment rails and catch trays, and others with glass top condiment rails and granite worktops, staff can easily create delicious food without leaving a single workstation, improve kitchen traffic flow, and maintain organization.

Refrigerated Prep Table with Sealed Condiment Rail

- Prep, store, and assemble sandwiches, salads, and more without leaving a single workstation
- Refrigerated sealed condiment rail allows for ingredients to stay fresh overnight
- Casters (2 locking) included for easy mobility
- Includes removable stainless steel grates and plastic catch trays



UCPT565-SS61A



UCPT588-SS61A

Model	Description	Voltage/Hz/Phase/Amps.	Shipping Weight
UCPT565-SS61A	65" 2 Door Refrigerated Prep Table + Sealed Condiment Rail	115v / 60hz / 1 / 7	653 lb
UCPT588-SS61A	88" 3 Door Refrigerated Prep Table + Sealed Condiment Rail	115v / 60hz / 1 / 9	741 lb

Specifications	
UCPT565-SS61A dimensions: 63 11/16" H x 65 5/16" W x 36 5/8" D	UCPT588-SS61A dimensions: 63 11/16" H x 88 5/16" W x 36 5/8" D
UCPT565-SS61A volume: 14.95 cu ft	UCPT588-SS61A volume: 21.89 cu ft
UCPT565-SS61A includes 4 epoxy coated wire shelves	UCPT588-SS61A includes 6 epoxy coated wire shelves
UCPT565-SS61A: high efficiency compressor	
UCPT588-SS61A: high efficiency compressor, side mount	
AISI 304 stainless steel interior & exterior	
Autodefrost	
Base temperature range: 28°F to 46°F	Condiment rail temperature range: 36°F to 50°F
CFC-free high-density polyurethane insulated cabinet	
Electronic digital temperature control with alarms	
Environmentally friendly 449a refrigerant: UCPT565-SS61A: 35 oz (1.0 kg) / UCPT588-SS61A: 49 oz (1.4 kg)	
Epoxy coated, sealed evaporator eliminates potential corrosion	
Factory pre-wired for dedicated outlet, 11 ft cord and plug included NEMA 5-15P	
Interior rounded corners for easy cleaning	
NSF/ANSI Standard 7 compliant	
Pans not included	
Self-lubricating, sealed cast iron evaporator fan motor with high volume airflow design	

Accessories	Description	Shipping Weight
ULA4082514	(1) Stainless steel shelf guide for prep tables, 24"	.88 lb
ULAQ32-4666-ETL	(1) Epoxy coated wire shelf, 17 7/8" x 25 7/8" for prep tables	2.2 lb

Front (2 Door)

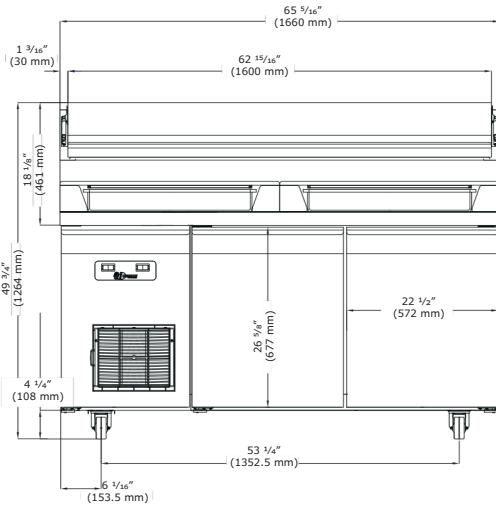

Front (3 Door)

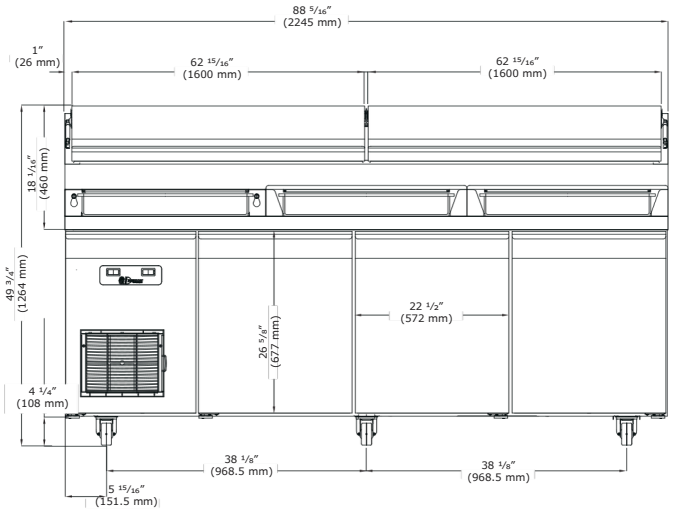

Side

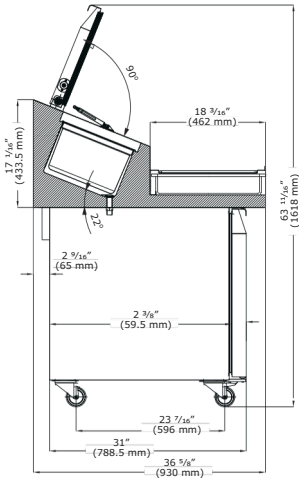

Top (2 Door)*

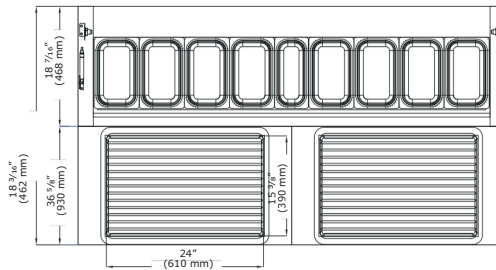

Top (3 Door)*

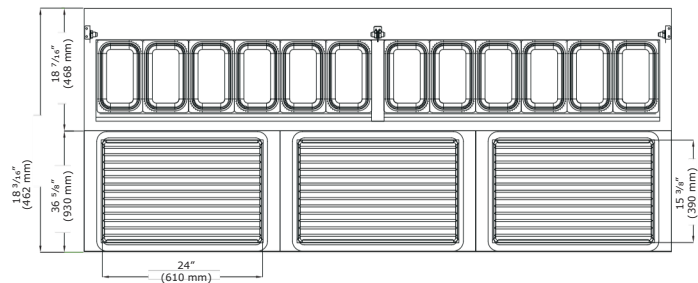

*Pans not included

Commercial Warranty

3 Year (parts & labor) / 5 year sealed system (parts)

See complete warranty for details



Sandwich Prep Tables

- Prep tables offer an all-in-one design solution for salad, sandwich and meal prep.
- Our trusted Sandwich Prep Tables give staff the confidence of keeping ingredients fresh.
- Casters (2 locking) included for easy mobility.
- Features a full-length white polythene cutting board that provides a dedicated space to prep ingredients.



UCSP127-SS11A



UCSP132-SS11A



UCSP148-SS61A



UCSP160-SS61A

Model	Description	Voltage/Hz/Phase/Amps	Shipping Weight
UCSP127-SS11A	27" Sandwich Prep Table (1 Door)	115v / 60hz / 1 / 3.4	242 lb
UCSP132-SS11A	32" Sandwich Prep Table (1 Door)	115v / 60hz / 1 / 3.4	264 lb
UCSP148-SS61A	48" Sandwich Prep Table (2 Doors)	115v / 60hz / 1 / 3.4	375 lb
UCSP160-SS61A	60" Sandwich Prep Table (2 Doors)	115v / 60hz / 1 / 3.4	462 lb

Specifications

UCSP127-SS11A: 27 1/2" W X 35 1/2" D X 42 1/2" H
UCSP132-SS11A: 32 1/2" W X 35 1/2" D X 42 1/2" H
UCSP148-SS61A: 48" W X 35 1/2" D X 42 1/2" H
UCSP160-SS61A: 60 1/2" W X 35 1/2" D X 42 1/2" H
UCSP127-SS11A: 1 PVC coated wire shelf (included with purchase) holds (1) 12" x 20" pan and (3) 1/6 pans, pan rail holds (8) 1/6 pans
UCSP132-SS11A: 1 PVC coated wire shelf (included with purchase) holds (2) 12" x 20" pans, pan rail holds (8) 1/6 pans
UCSP148-SS61A: 2 PVC coated wire shelves (included with purchase) each hold (1) 12" x 20" pan and (3) 1/9 pans, pan rail holds (12) 1/6 pans
UCSP160-SS61A: 2 PVC coated wire shelves (included with purchase) each hold (1) 12" x 20" pan, (3) 1/6 pans and (3) 1/9 pans, pan rail holds (16) 1/6 pans
AISI 304 stainless steel interior and exterior
Autodefrost
CFC-free high-density polyurethane insulated cabinet
Electronic digital temperature control with alarms
Environmentally friendly R290 refrigerant
Factory pre-wired for dedicated outlet, 10 ft cord and plug included NEMA 5-15P
High efficiency compressor, side mount
High efficiency evaporator coil & condenser
NSF/ANSI Standard 7 compliant
Pan rail accommodates either 4" or 6" tall pans
Self-lubricating, sealed cast iron evaporator fan motor with high volume airflow design
Temperature range: 28°F to 46°F

Front (UCSP127-SS11A)

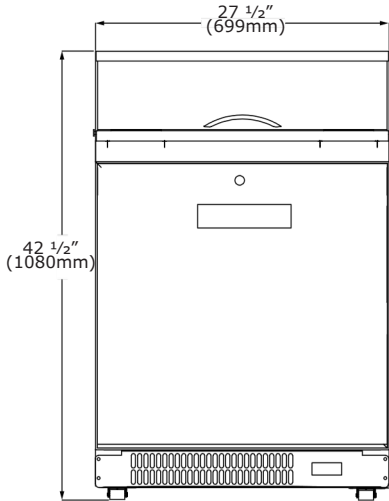

Front (UCSP132-SS11A)

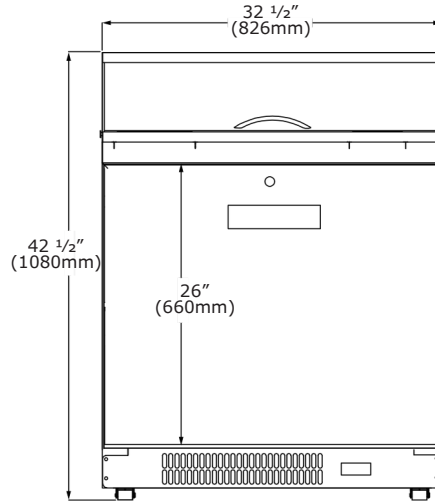

Side (All Models)

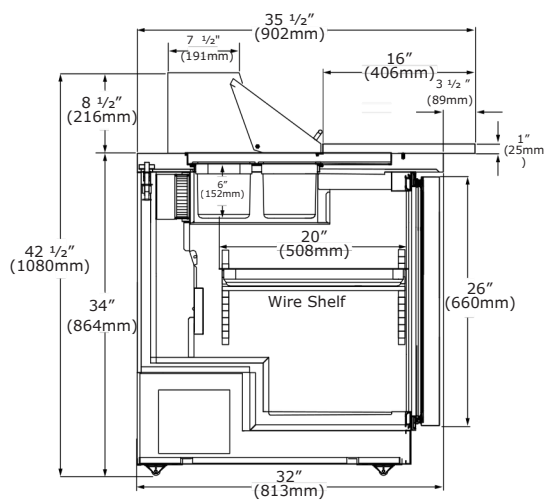

Top Rail (UCSP127-SS11A)

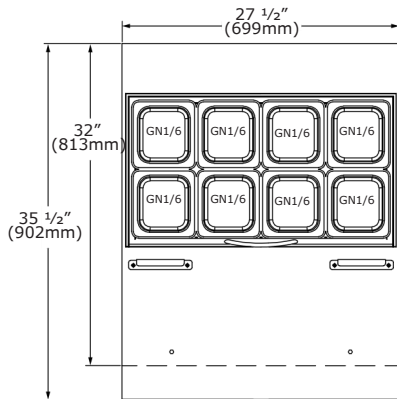

Top Rail (UCSP132-SS11A)

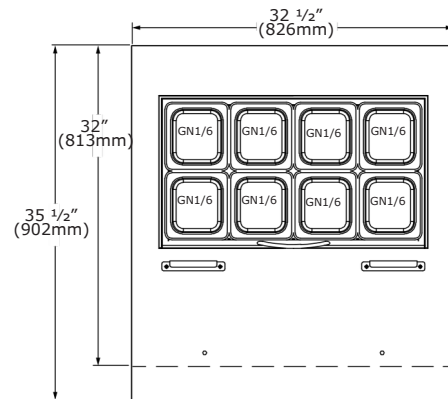

Door Interior (UC SP127-SS11A)

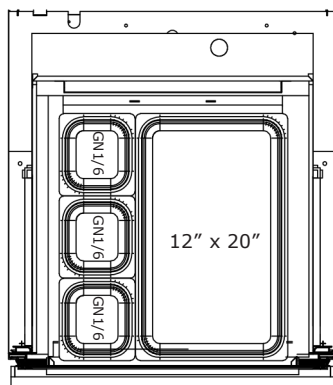

Door Interior (UC SP132-SS11A)

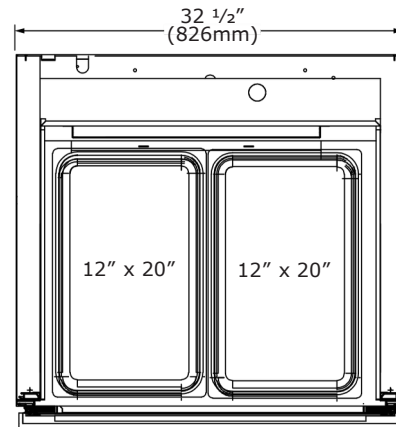

Front (UCSP148-SS61A)

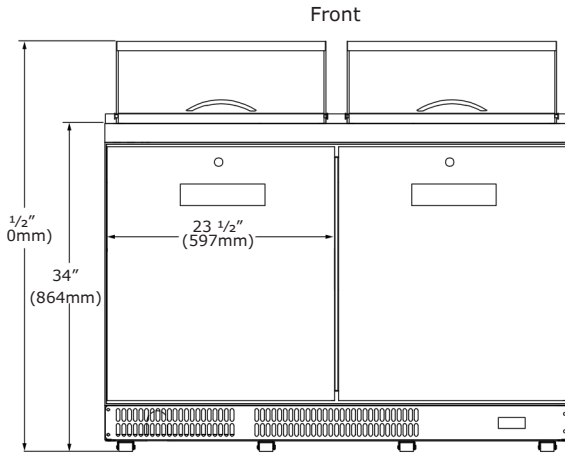

Front (UCSP160-SS61A)

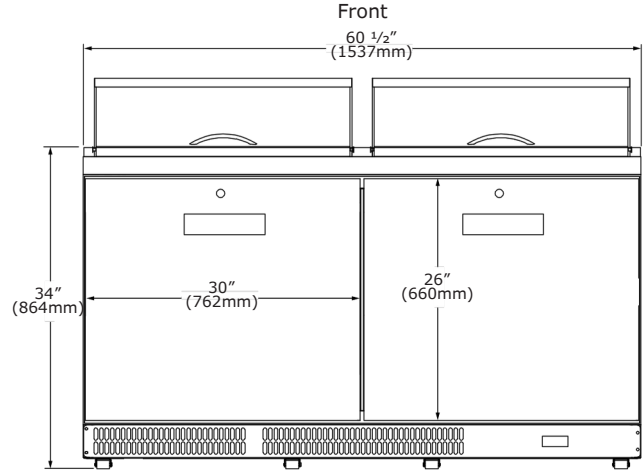

Top Rail (UCSP148-SS61A)

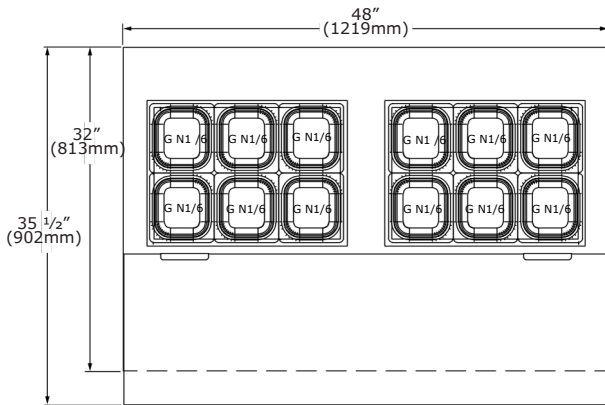

Top Rail (UCSP160-SS61A)

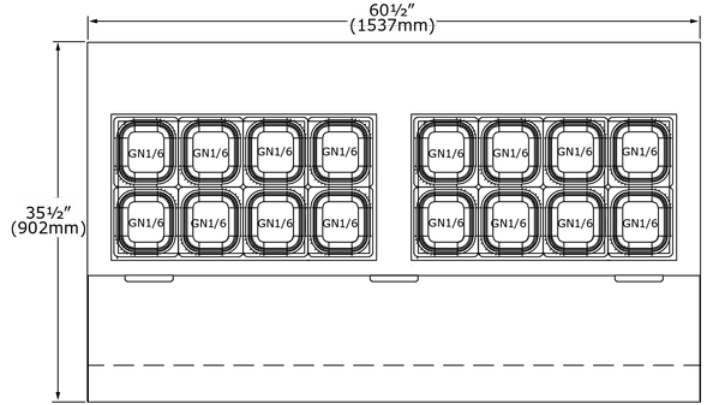

Door Interior (UC SP148-SS61A)

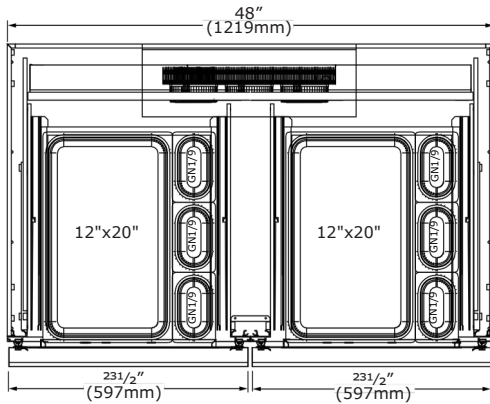

Door Interior (UC SP160-SS61A)

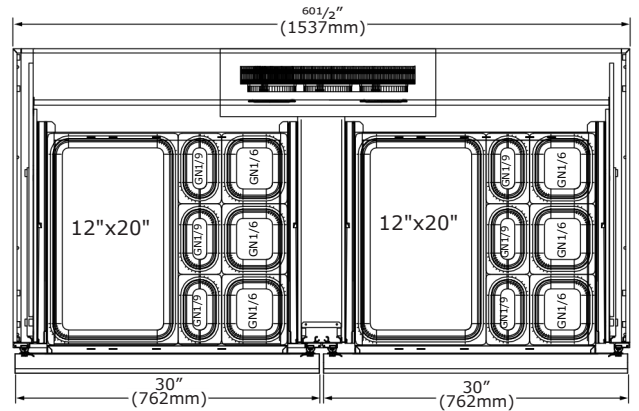

Commercial Warranty

3 Year (parts & labor) / 5 year sealed system (parts)
See complete warranty for details



Sandwich Prep Tables with Drawers

- Prep tables offer an all-in-one design solution for salad, sandwich and meal prep.
- Our trusted Sandwich Prep Tables give staff the confidence of keeping ingredients fresh.
- Casters (2 locking) included for easy mobility.
- Features a full-length white polythene cutting board that provides a dedicated space to prep ingredients.



UCSP127-SS91A



UCSP132-SS91A



UCSP148-SS91A



UCSP160-SS91A

Model	Description	Voltage/Hz/Phase/Amps	Shipping Weight
UCSP127-SS91A	27" Sandwich Prep Table (2 Drawers)	115v / 60hz / 1 / 3.4	264 lb
UCSP132-SS91A	32" Sandwich Prep Table (2 Drawers)	115v / 60hz / 1 / 3.4	286 lb
UCSP148-SS91A	48" Sandwich Prep Table (4 Drawers)	115v / 60hz / 1 / 3.4	408 lb
UCSP160-SS91A	60" Sandwich Prep Table (4 Drawers)	115v / 60hz / 1 / 3.4	507 lb

Specifications

UCSP127-SS91A: 27 1/2" W X 35 1/2" D X 42 1/2" H
UCSP132-SS91A: 32 1/2" W X 35 1/2" D X 42 1/2" H
UCSP148-SS91A: 48" W X 35 1/2" D X 42 1/2" H
UCSP160-SS91A: 60 1/2" W X 35 1/2" D X 42 1/2" H
UCSP127-SS91A: Each drawer holds (1) 12" x 20" pan and (3) 1/6 pans, pan rail holds (8) 1/6 pans
UCSP132-SS91A: Each drawer holds (2) 12"x 20" pans, pan rail holds (8) 1/6 pans
UCSP148-SS91A: Each drawer holds (1) 12" x 20" pan and (3) 1/9 pans, pan rail holds (12) 1/6 pans
UCSP160-SS91A: Each drawer holds (1) 12" x 20" pan, (3) 1/6 pans and (3) 1/9 pans, pan rail holds (16) 1/6 pans
AISI 304 stainless steel interior and exterior
Autodefrost
Bottom drawer accommodates 4" tall pans
CFC-free high-density polyurethane insulated cabinet
Electronic digital temperature control with alarms
Environmentally friendly R290 refrigerant
Factory pre-wired for dedicated outlet, 10 ft cord and plug included
NEMA 5-15P High efficiency compressor, side mount
High efficiency evaporator coil & condenser
NSF/ANSI Standard 7 compliant
Pan rail accommodates either 4" or 6" tall pans
Self-lubricating, sealed cast iron evaporator fan motor with high volume airflow design
Temperature range: 28°F to 46°F
Top drawer accommodates 6" tall pans

Front (UCSP127-SS91A)

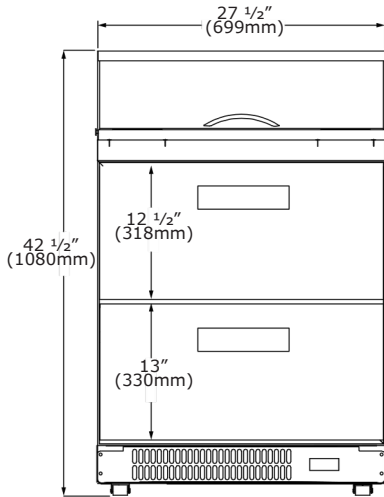

Front (UCSP132-SS91A)

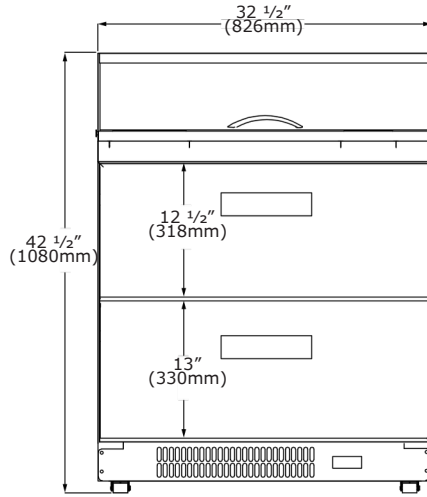

Side (All Models)

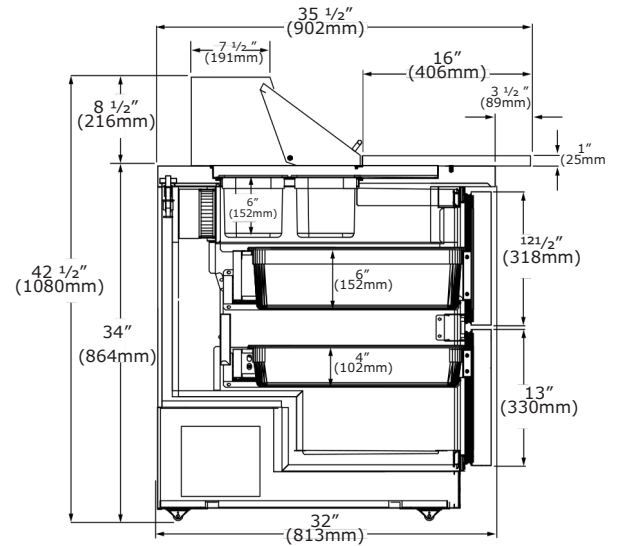

Top Rail (UCSP127-SS91A)

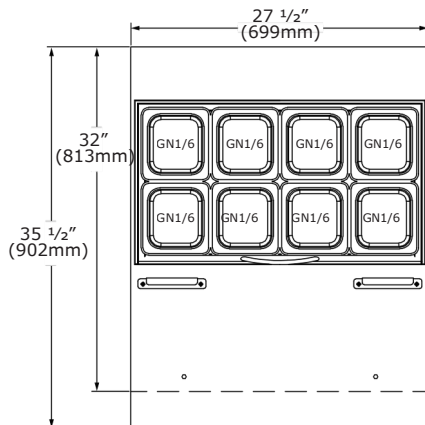

Top Rail (UCSP132-SS91A)

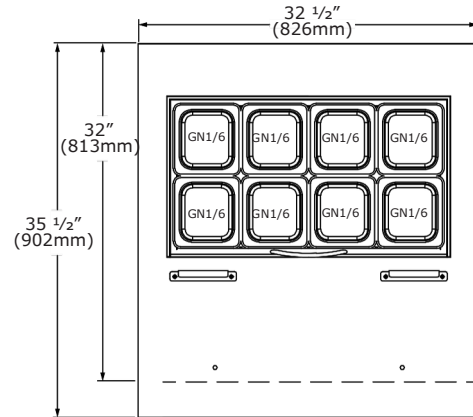

Drawer Interior (UC SP127-SS91A)

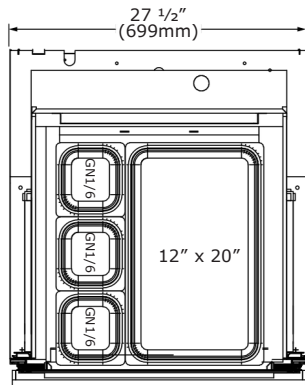

Drawer Interior (UCSP132-SS91A)

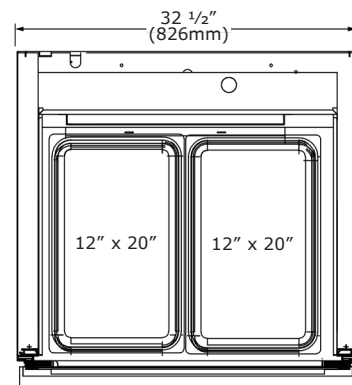

Front (UCSP148-SS91A)

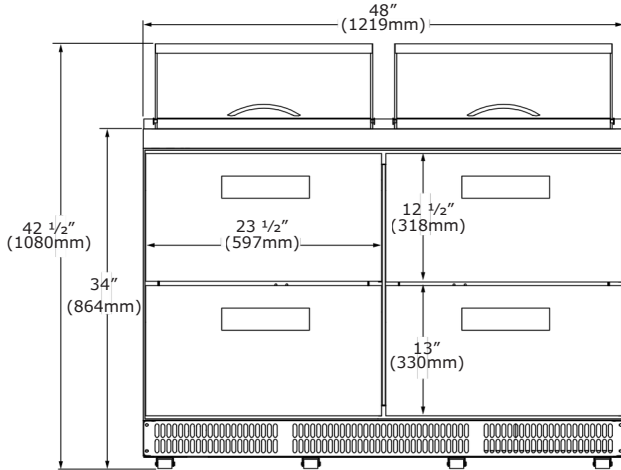

Front (UCSP160-SS91A)

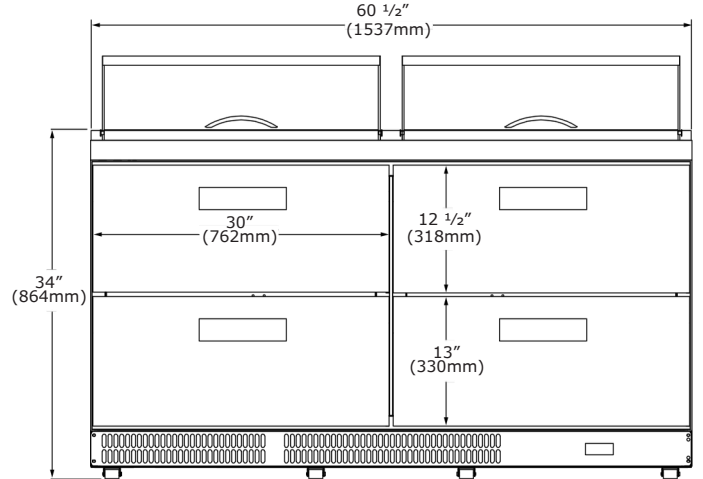

Top Rail (UCSP148-SS91A)

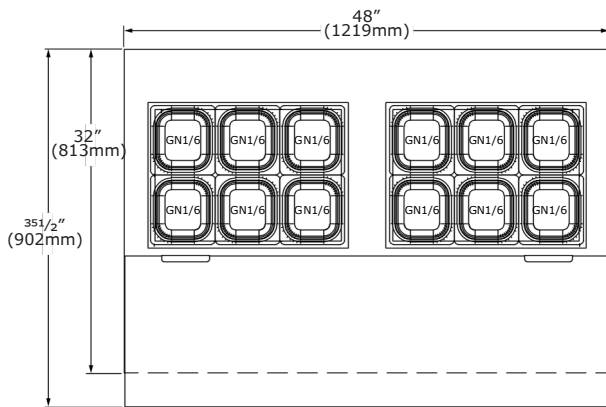

Top Rail (UCSP160-SS91A)

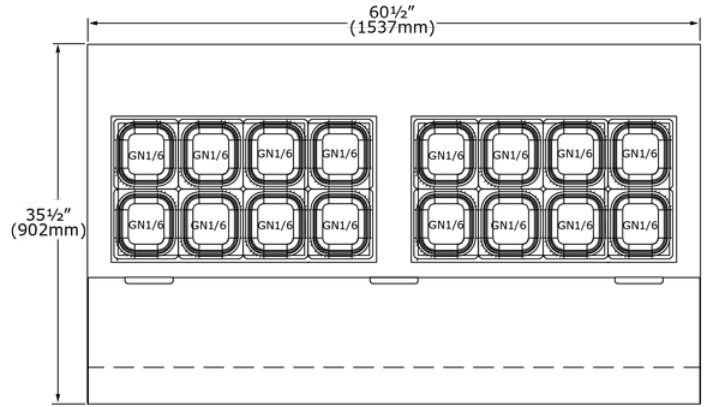

Drawer Interior (UCSP148-SS91A)

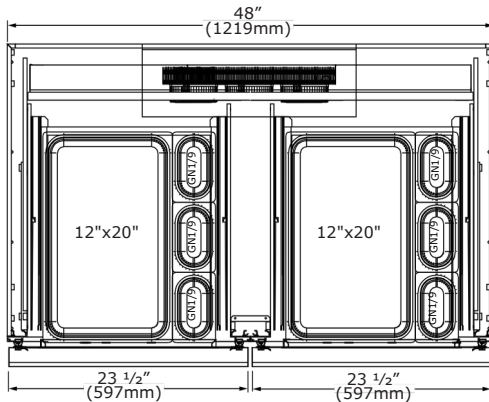

Drawer Interior (UCSP160-SS91A)

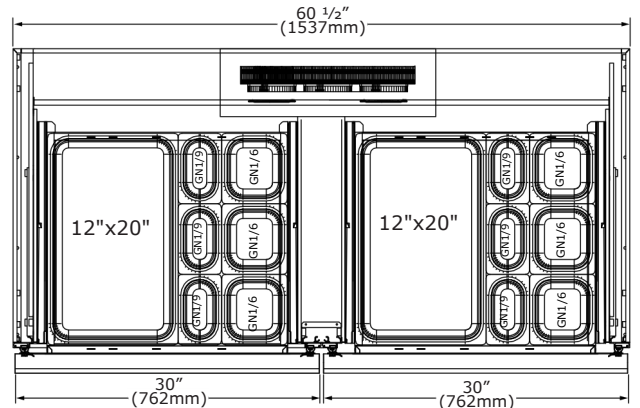

Commercial Warranty

3 Year (parts & labor) / 5 year sealed system (parts)
See complete warranty for details





Pass-Thru Refrigerators

REFRIGERATION SOLUTIONS

Pass-Thru refrigerators are a key component of any cafeteria kitchen, optimizing and streamlining operations. These refrigerators feature multiple access points, allowing kitchen staff to load supplies from one side and retrieve them from the other, facilitating a smooth flow and minimizing disruptions to food preparation processes. This multi-access design contributes to improved organization and inventory management, as staff can easily monitor to maintain freshness and quality. Designed for easy cleaning and maintenance, with accessible interior compartments that simplify upkeep tasks. With their combination of practical functionality, durability, and reliability in a wide variety of options, QualServ's collection of Pass-Thru refrigerators prove to be assets in any kitchen, contributing to smoother operations and ensuring the efficient delivery of high-quality meals.

25 cu ft Pass-Thru Refrigerators, Reach-In

- Key component to any high-volume cafeteria or commissary kitchen.
- Refill products from the back and serve from the front, creating efficiency in the kitchen or serving line.
- Available in solid door, glass door, and half-door combination options.



UCRP125-SS31A



UCRP125-GS31A



UCRP225-SS31A



UCRP225-GS31A



UCRP125-GG31A

Model	Description	Voltage/Hz/Phase/Amps.	Shipping Weight
UCRP125-SS31A	25 cu ft Pass-Thru Refrigerator, 1 Front Door Solid, 1 Back Door Solid	115v / 60hz / 1 / 3.4	355 lb
UCRP125-GS31A	25 cu ft Pass-Thru Refrigerator, 1 Front Door Glass, 1 Back Door Solid	115v / 60hz / 1 / 3.4	355 lb
UCRP225-SS31A	25 cu ft Pass-Thru Refrigerator, 2 Half Front Door Solid, 2 Half Back Door Solid	115v / 60hz / 1 / 3.4	355 lb
UCRP225-GS31A	25 cu ft Pass-Thru Refrigerator, 2 Half Front Door Glass, 2 Half Back Door Solid	115v / 60hz / 1 / 3.4	355 lb
UCRP125-GG31A	25 cu ft Pass-Thru Refrigerator, 1 Front Door Glass, 1 Back Door Glass	115v / 60hz / 1 / 3.4	355 lb

Specifications

Dimensions: 83 1/4" H x 28 3/8" W x 32" D (doors closed), 84 1/16" D (doors open)
AISI 304 stainless steel interior and exterior with locks
Autodefrost
CFC-free high-density polyurethane insulated cabinet
Environmentally friendly R290 refrigerant: 3.5 oz (0.100kg)
Electronic digital temperature control with alarms
Factory pre-wired for dedicated outlet, 11 ft cord and plug included NEMA 5-15P
High efficiency compressor, top mount
High efficiency evaporator coil & condenser
LED interior lighting
NSF/ANSI Standard 7 compliant
Self-lubricating, sealed cast iron evaporator fan motor with high volume airflow design
Temperature range: 28°F to 46°F
Volume of 25 cu ft 1 section, includes 6 pairs of L style tray guides (trays not included)

Accessories	Description	Shipping Weight
ULAPS4181145	(1) Stainless steel L-shaped shelf guide	1 lb

Front

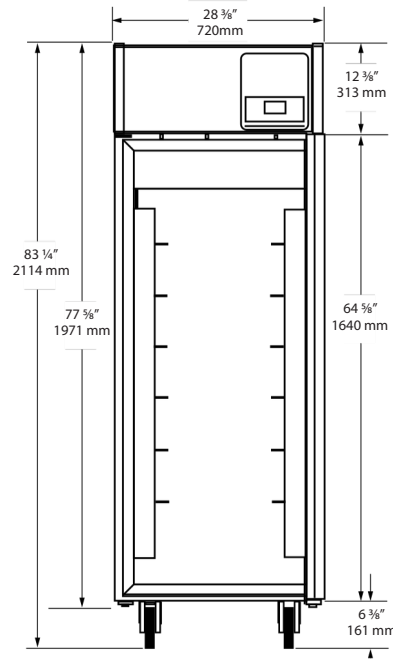

Side

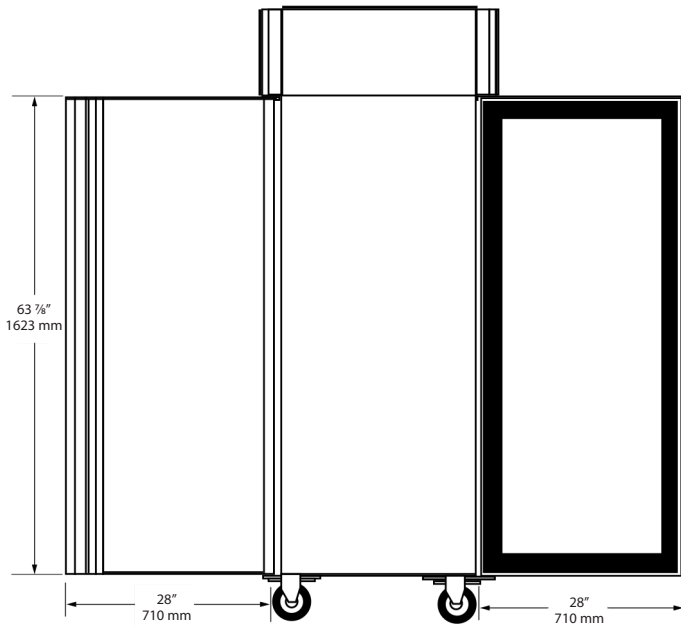

Top

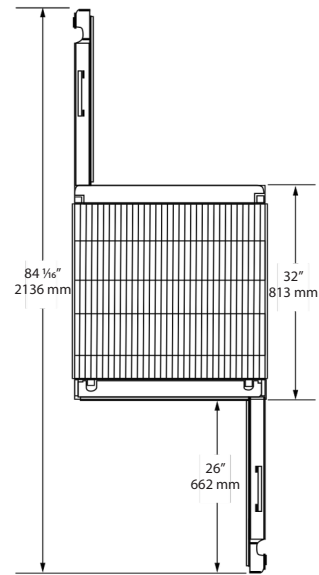

Commercial Warranty

3 Year (parts & labor) / 5 year sealed system (parts)

See complete warranty for details

49 cu ft Pass-Thru Refrigerators, Reach-In

- Key component to any high-volume cafeteria or commissary kitchen.
- Refill products from the back and serve from the front, creating efficiency in the kitchen or serving line.
- Available in solid door, glass door, and half-door combination options.



UCRP149-SS71A



UCRP149-GS71A



UCRP249-SS71A



UCRP249-GS71A



UCRP149-GG71A

Model	Description	Voltage/Hz/Phase/Amps.	Shipping Weight
UCRP149-SS71A	49 cu ft Pass-Thru Refrigerator, 2 Front Door Solid, 2 Back Door Solid	115v / 60hz / 1 / 6.4	440 lb
UCRP149-GS71A	49 cu ft Pass-Thru Refrigerator, 2 Front Door Glass, 2 Back Door Solid	115v / 60hz / 1 / 6.4	440 lb
UCRP249-SS71A	49 cu ft Pass-Thru Refrigerator, 4 Half Front Door Solid, 4 Half Back Door Solid	115v / 60hz / 1 / 6.4	440 lb
UCRP249-GS71A	49 cu ft Pass-Thru Refrigerator, 4 Half Front Door Glass, 4 Half Back Door Solid	115v / 60hz / 1 / 6.4	440 lb
UCRP149-GG71A	49 cu ft Pass-Thru Refrigerator, 2 Front Door Glass, 2 Back Door Glass	115v / 60hz / 1 / 6.4	440 lb

Specifications

Dimensions: 83 1/4" H x 56 11/16" W x 32" D (doors closed), 84 1/16" D (doors open)

AISI 304 stainless steel interior and exterior with locks

Autodefrost

CFC-free high-density polyurethane insulated cabinet

Environmentally friendly R290 refrigerant: 3.5 oz (0.100kg)

Electronic digital temperature control with alarms

Factory pre-wired for dedicated outlet, 11 ft cord and plug included NEMA 5-15P

High efficiency compressor, top mount

High efficiency evaporator coil & condenser

LED interior lighting

NSF/ANSI Standard 7 compliant

Self-lubricating, sealed cast iron evaporator fan motor with high volume airflow design

Temperature range: 28°F to 46°F

Volume of 49 cu ft 2 sections, includes 12 pairs of L style tray guides (trays not included)

Front

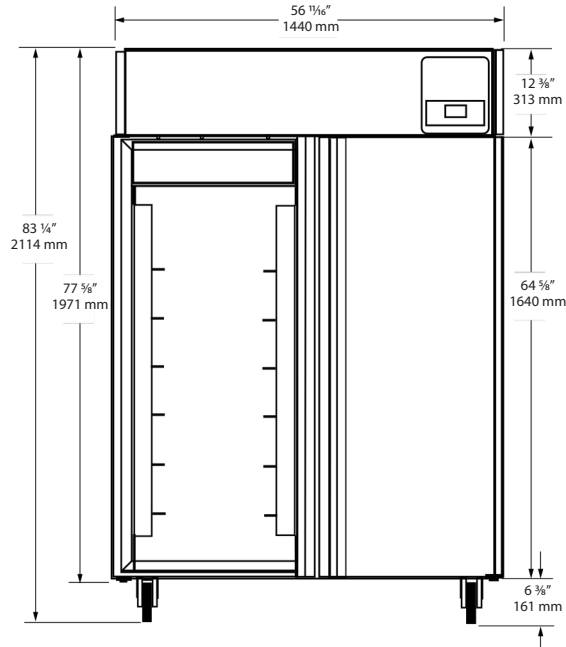

Side

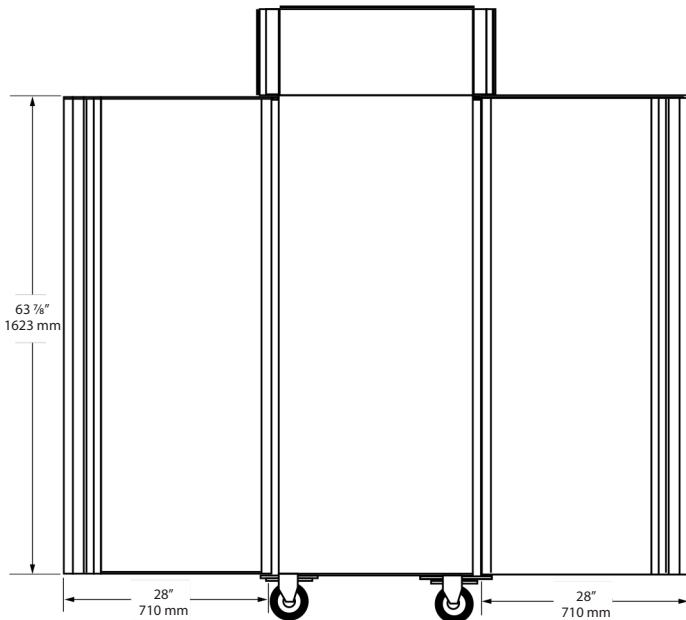

Top

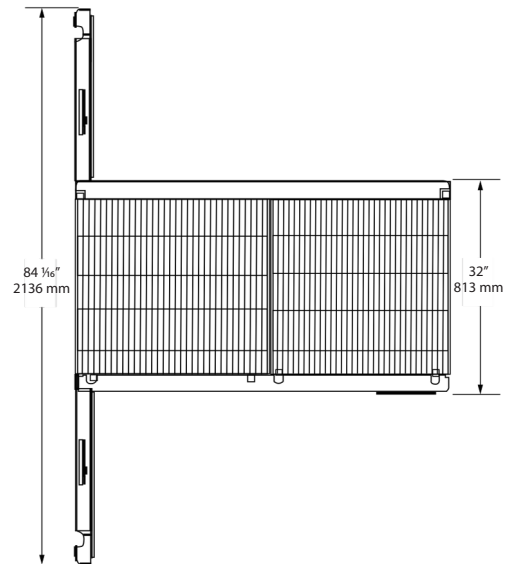

Commercial Warranty

3 Year (parts & labor) / 5 year sealed system (parts)

See complete warranty for details



Pizza Prep Tables

REFRIGERATION SOLUTIONS

Our pizza prep table refrigerators offer a tailored solution for any kitchen, combining convenience, functionality, and efficiency in food preparation processes. These specialized refrigerators are designed with dedicated compartments to accommodate ingredients and food preparation supplies, providing chefs and kitchen staff with easy access to essential items during meal assembly.

When a worldwide brand's corporate headquarters needed a way to quickly feed employees in their cafeteria, they found the ultimate solution by installing three QualServ pizza prep tables to help serve their team so they can refuel and go about their day. Studies show that nutritious meals help generate ideas, stimulate minds, and build teamwork.

Refrigerated Pizza Prep Table with Condiment Rail

- Prep, store, and assemble pizzas with a refrigerated prep-table with granite top and glass-top condiment rail
- Improve kitchen flow and maintain organization
- Have toppings cool, visible, and within reach – streamlining service
- Casters (2 locking) included for easy mobility



UCPP566-SS61A



UCPP588-SS61A

Model	Description	Voltage/Hz/Phase/Amps	Shipping Weight
UCPP566-SS61A	65" 2 Door Refrigerated Pizza Prep Table + Condiment Rail	115v / 60hz / 1 / 6.5	772 lb
UCPP588-SS61A	88" 3 Door Refrigerated Pizza Prep Table + Condiment Rail	115v / 60hz / 1 / 6.5	992 lb

Specifications	
UCPP566-SS61A dimensions: 63 15/16" H x 65 1/8" W x 31 1/8" D	UCPP588-SS61A dimensions: 63 15/16" H x 88 11/32" W x 31 1/8" D
UCPP566-SS61A volume: 14 cu ft	UCPP588-SS61A volume: 21.89 cu ft
UCPP566-SS61A includes 4 epoxy coated wire shelves	UCPP588-SS61A includes 6 epoxy coated wire shelves
AISI 304 stainless steel interior and exterior with granite worktop and refrigerated condiment rail, ETL sanitation certified	
Autodefrost	
CFC-free high-density polyurethane insulated cabinet	
Electronic digital temperature control with alarms	
Environmentally friendly R449a/R134a (top) refrigerant: UCPP566-SS61A: 10.6 oz (0.280 kg) / 7.0 oz (0.200 kg) UCPP588-SS61A: 17.5 oz (0.500 kg) / 8.8 oz (0.250 kg)	
Factory pre-wired for dedicated outlet, 11 ft cord and plug included NEMA 5-15P	
Glass-top assembly required	
High efficiency compressor, side mount	
High efficiency evaporator coil & condenser	
Interior rounded corners for easy cleaning	
NSF/ANSI Standard 7 compliant	
Pans not included	
Self-lubricating, sealed cast iron evaporator fan motor with high volume airflow design	
Temperature range: 28°F to 46°F	

Accessories	Description	Shipping Weight
ULA4082514	(1) Stainless steel shelf guide for prep tables, 24"	.88 lb
ULAQ32-4666-ETL	(1) Epoxy coated wire shelf, 17 7/8" x 25 7/8" for prep tables	2.2 lb

Front (2 Door with Condiment Rail)

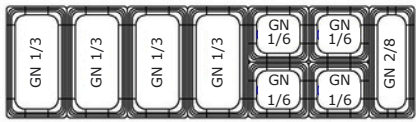
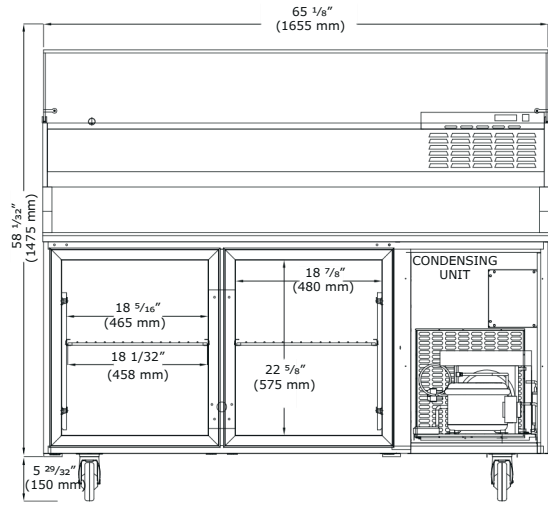

UCPP566-SS61A condiment rail (for reference only - pans not included)

Side

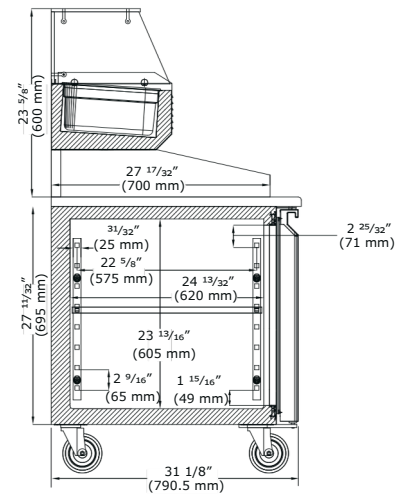

Front (3 Door with Condiment Rail)

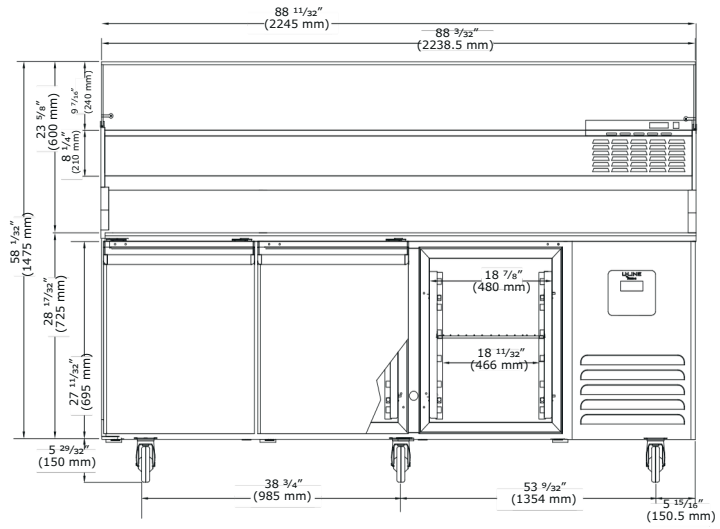

UCPP588-SS61A condiment rail (for reference only - pans not included)

Top

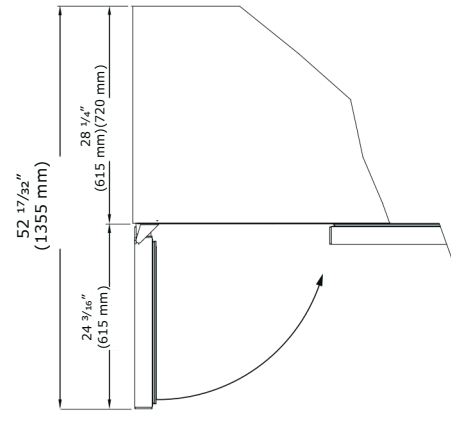

Commercial Warranty

3 Year (parts & labor) / 5 year sealed system (parts)
See complete warranty for details



Refrigerated Pizza Prep Table with Cold Wall Sealed Condiment Rail

- Prep, store, and assemble pizzas with a refrigerated prep-table with cold wall sealed glass-top condiment rail
- Refrigerated sealed condiment rail allows for ingredients to stay fresh overnight
- Marble top with round sauce pan
- Casters (2 locking) included for easy mobility



UCPS568-SS61A



UCPS572-SS61A



UCPS596-SS61A

Model	Description	Voltage/Hz/Phase/Amps	Shipping Weight
UCPS568-SS61A	68" 2 Door Refrigerated Pizza Prep Table + Cold Wall Sealed Condiment Rail	115v / 60hz / 1 / 8	871 lbs
UCPS572-SS61A	72" 2 Door Refrigerated Pizza Prep Table + Cold Wall Sealed Condiment Rail	115v / 60hz / 1 / 8	893 lbs
UCPS596-SS61A	96" 3 Door Refrigerated Pizza Prep Table + Cold Wall Sealed Condiment Rail	115v / 60hz / 1 / 9	1213 lbs

Specifications	
UCPS568-SS61A dimensions: 63" H x 68" W x 34 1/2" D	UCPS568-SS61A volume: 13.94 cu ft
UCPS572-SS61A dimensions: 63" H x 72" W x 34 1/2" D	UCPS572-SS61A volume: 13.94 cu ft
UCPS596-SS61A dimensions: 63" H x 96" W x 34 1/2" D	UCPS596-SS61A volume: 21 cu ft
1/3 size adapter bars for top opening supplied	
AISI 304 stainless steel interior and exterior with refrigerated condiment rail, ETL sanitation certified	
Autodefrost	
CFC-free high-density polyurethane insulated cabinet	
Electronic digital temperature control with alarms	
Environmentally friendly R449a refrigerant: UCPS568-SS61A & UCPS572-SS61A: 35 oz (1.0 kg); UCPS596-SS61A: 49 oz (1.4 kg)	
Epoxy coated, sealed evaporator eliminates potential corrosion	
Factory pre-wired for dedicated outlet, 11 ft cord and plug included NEMA 5-15P	
High efficiency compressor, side mount	
Includes 1 epoxy coated wire shelf standard, per door section	
Interior rounded corners for easy cleaning	
NSF/ANSI Standard 7 compliant	
Pans not included	
Self-lubricating, sealed cast iron evaporator fan motor with high volume airflow design	
Temperature ranges: Base 28°F to 46°F Condiment rail: 35°F to 50°F	

Accessories	Description	Shipping Weight
ULA4082514	(1) Stainless steel shelf guide for prep tables, 24"	.88 lb
ULAQ32-4666-ETL	(1) Epoxy coated wire shelf, 17 7/8" x 25 7/8" for prep tables	2.2 lb

68"

Front

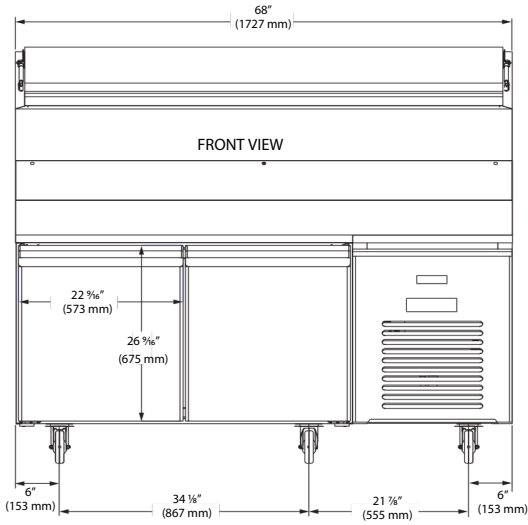

Side

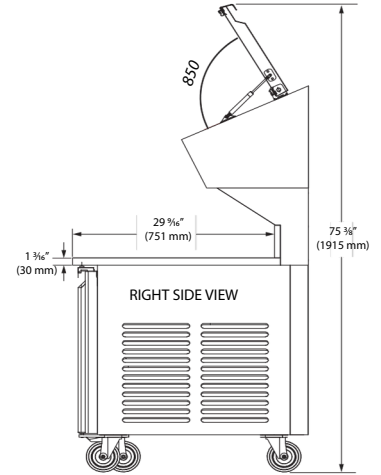
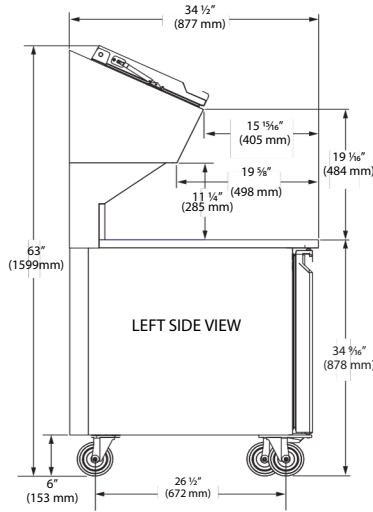

72"

Front

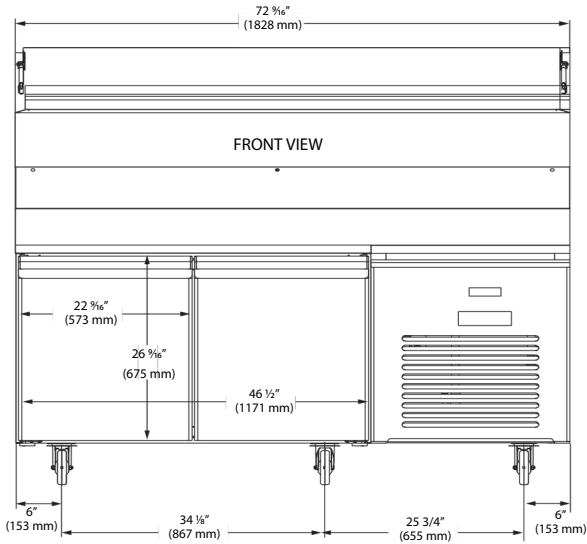

Side

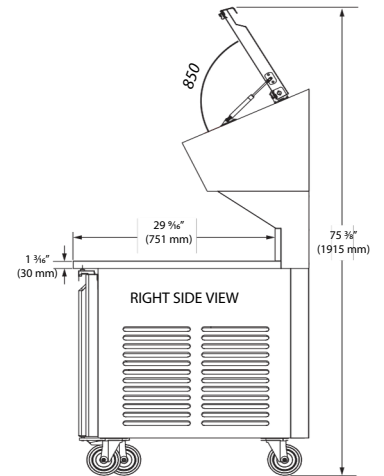
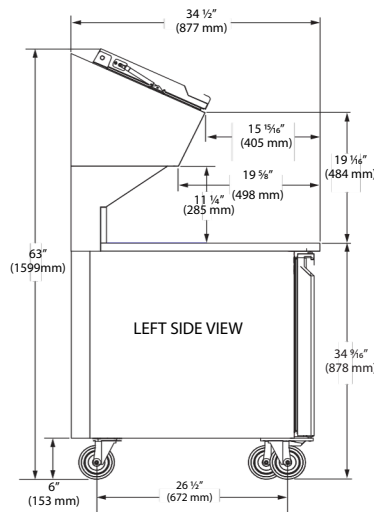

UCPS568-SS61A & UCPS572-SS61A condiment rail
(for reference only - pans not included)

Refrigerated Pizza Prep-Table

- Prep, store, and assemble pizzas with a refrigerated prep-table with granite top
- Create delicious pizzas without leaving a single workstation
- Improve kitchen flow and maintain organization
- Available in 2 and 3 door configurations
- Casters (2 locking) included for easy mobility



UCPP466-SS61A



UCPP488-SS61A

Model	Description	Voltage/Hz/Phase/Amps	Shipping Weight
UCPP466-SS61A	65" 2 Door Refrigerated Pizza Prep Table	115v / 60hz / 1 / 5	662 lb
UCPP488-SS61A	88" 3 Door Refrigerated Pizza Prep Table	115v / 60hz / 1 / 5	882 lb

Specifications	
UCPP466-SS61A dimensions: 40 5/16" H x 65 1/8" W x 31 15/32" D	UCPP488-SS61A dimensions: 40 5/16" H x 88 3/8" W x 31 15/32" D
UCPP466-SS61A volume: 14 cu ft	UCPP488-SS61A volume: 21.89 cu ft
UCPP466-SS61A includes 2 epoxy coated wire shelves	UCPP488-SS61A includes 3 epoxy coated wire shelves
AISI 304 stainless steel interior and exterior with granite worktop, ETL sanitation certified	
Autodefrost	
CFC-free high-density polyurethane insulated cabinet	
Electronic digital temperature control with alarms	
Environmentally friendly R449a refrigerant: UCPP466-SS61A: 10.6 oz (0.280 kg) / CPP488: 17.5 oz (0.500 kg)	
Epoxy coated, sealed evaporator eliminates potential corrosion	
Factory pre-wired for dedicated outlet, 11 ft cord and plug included NEMA 5-15P	
High efficiency compressor, side mount	
Interior rounded corners for easy cleaning	
NSF/ANSI Standard 7 compliant	
Self-lubricating, sealed cast iron evaporator fan motor with high volume airflow design	
Temperature range: 28°F to 46°F	

Accessories	Description	Shipping Weight
ULA4082514	(1) Stainless steel shelf guide for prep tables, 24"	.88 lb
ULAQ32-4666-ETL	(1) Epoxy coated wire shelf, 17 7/8" x 25 7/8" for prep tables	2.2 lb

Front (2 Door)

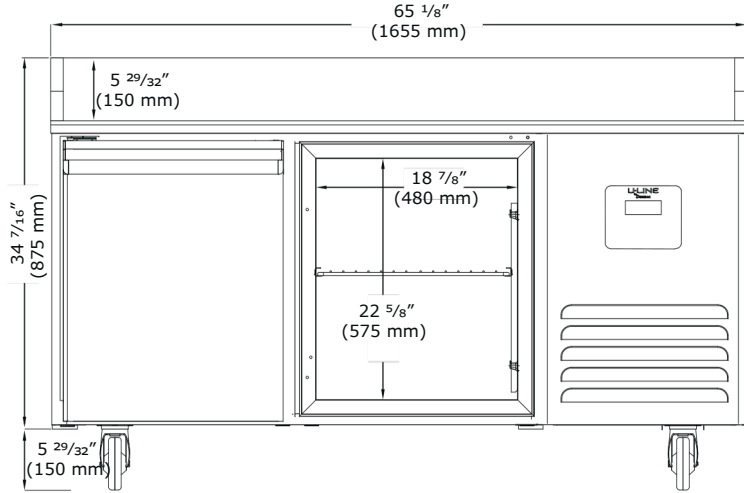

Side

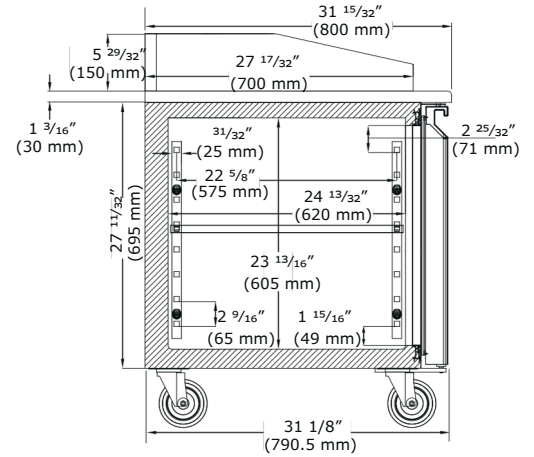

Front (3 Door)

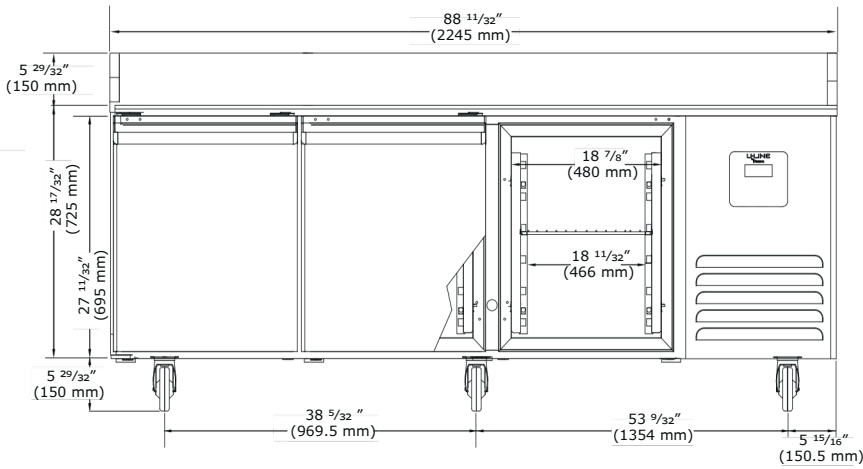

Top

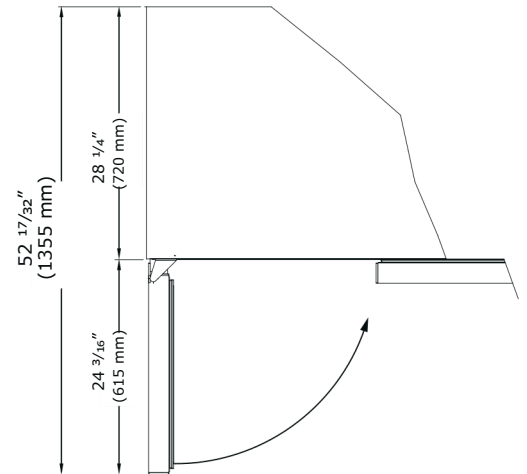

Commercial Warranty

3 Year (parts & labor) / 5 year sealed system (parts)

See complete warranty for details



Glass-Top Refrigerated Condiment Rails

- Keep fresh ingredients within reach for easy assembly of pizzas, sandwiches, and more
- Electronic control for ease of use
- Aids in kitchen efficiency



UCGAC166



UCGAC223

Model	Description	Voltage/Hz/Phase/Amps	Shipping Weight
UCGAC166	Glass-Top Refrigerated Condiment Rail - 66"	115 / 60 / 1 / 1.5	137 lb
UCGAC223	Glass-Top Refrigerated Condiment Rail - 88"	115 / 60 / 1 / 1.5	165 lb

Specifications

UCGAC166 storage capacity: 7 GN 1/3 pans (not included)
UCGAC223 storage capacity: 10 GN 1/3 pans (not included)
Environmentally friendly R134a refrigerant: UCGAC166: 7.0 oz (0.200 kg) / UCGAC223: 8.8 oz (0.250 kg)
Factory pre-wired for dedicated outlet, 11 ft cord and plug included NEMA 5-15P
Glass-top assembly required
NSF/ANSI Standard 7 compliant
Stainless Steel and Glass Construction
Temperature range: 28°F to 46°F

Commercial Warranty

3 Year (parts & labor) / 5 year sealed system (parts)
See complete warranty for details



6 Drawer Ambient Dough Cabinet

- Prep table storage companion
- Perfect for pizza dough or to store additional utensils, cutting boards or trays
- Features 6 storage drawers
- 4 casters (2 locking) included for easy mobility



UCCATP

Top

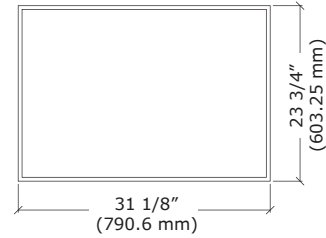

Front

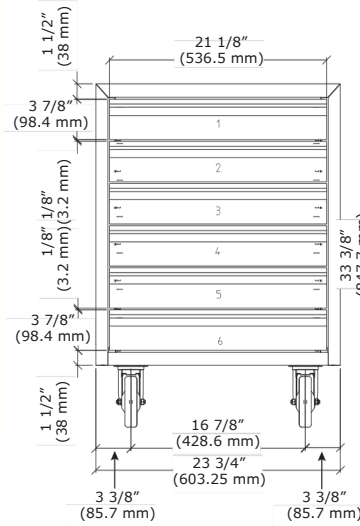

Side

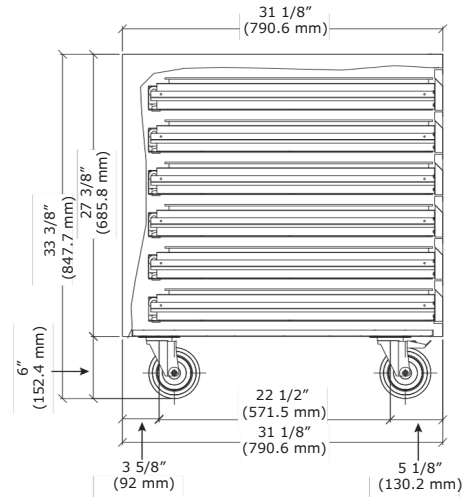

Model	Description	Shipping Weight
UCCATP	6 Drawer Ambient Dough Cabinet	132 lb

Specifications

UCCATP dimensions: 33 7/8" H X 23 3/4" W X 31 1/8" D
AISI 304 stainless steel interior and exterior
Holds up to 6 dough boxes (25 5/8" W X 18" D X 3 1/4" H)
NSF/ANSI Standard 7 compliant

Commercial Warranty

3 Year (parts & labor) / 5 year sealed system (parts)
See complete warranty for details



Reach-In Refrigerators & Freezers

REFRIGERATION SOLUTIONS

QualServ commercial reach-in refrigerators and freezers are the foundation to any kitchen or foodservice operation. These appliances are crafted to provide ample storage space while maintaining optimal temperature levels, ensuring that perishable ingredients and food items remain fresh and safe. QualServ reach-in refrigerators and freezers accommodate a diverse range of food products, allowing chefs and kitchen staff to organize and store ingredients according to their specific needs. Whether used in restaurants, catering services, or institutional kitchens, our products optimize workflow and contribute to seamless operations.

Available in a wide variety of sizes with glass and solid door options, QualServ offers trusted reach-in freezers and refrigerators that give staff confidence in keeping ingredients and prepared foods fresh. Featuring easy-to-use controls, stainless steel interiors and exteriors, and high-performance compressors, our thoughtfully designed refrigeration will improve the flow and function of your space.



25 cu ft Refrigerator, Reach-In

- Improve the flow and function of your space by having refrigerated items where you need them most
- Comfortably fits 18" x 26" sheet pans (not included)
- 4 casters included (2 locking) for easy mobility



UCRE427-SS01A

Model	Description	Voltage/Hz/Amps	Shipping Weight
UCRE427-SS01A	25 cu ft Refrigerator, Reach-In, Field Reversible Hinge	115v / 60hz / 3.8	287 lb

Specifications

UCRE427-SS01A dimensions: 80 23/32" H x 27 9/16" W x 31 1/2" D
AISI 441 stainless steel interior and exterior with lock
Autodefrost
CFC-free high-density polyurethane insulated cabinet
Environmentally friendly R290 refrigerant: 3.2 oz (0.090kg)
Electronic digital temperature control with alarms
Factory pre-wired for dedicated outlet, 11 ft cord and plug included NEMA 5-15P
High efficiency compressor, top mount
High efficiency evaporator coil & condenser
NSF/ANSI Standard 7 compliant
Self-lubricating, sealed cast iron evaporator fan motor with high volume airflow design
Temperature range: 28°F to 46°F
Volume of 25 cu ft
1 section, includes 3 epoxy coated wire shelves

Accessories	Description	Shipping Weight
ULA4080584	(1) Stainless steel shelf guide for all reach-ins except UCRE553 & UCFZ553, 24 3/4"	.88 lb
ULAQ32-0002	(1) Epoxy coated wire shelf, 20 7/8" x 25 5/8" for reach-ins	7 lb
ULA89020410	Stainless steel adjustable leg kit includes 4 legs, 4 5/8" H to 7 1/8" H, M6 bolts	11.02 lb
ULA80110300	Interior LED lighting kit for solid door reach-ins	2.2 lb

Front (Open)

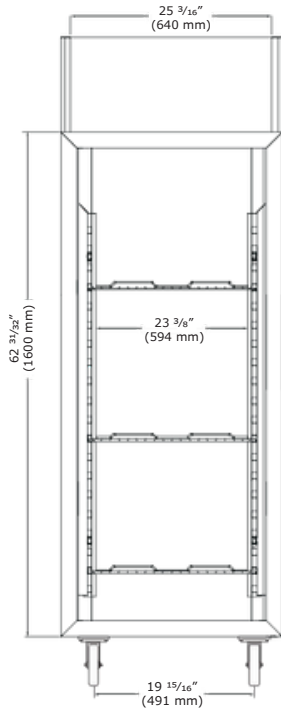

Front (Closed)

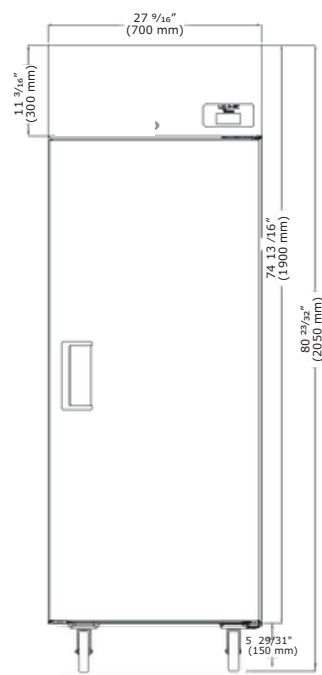

Top

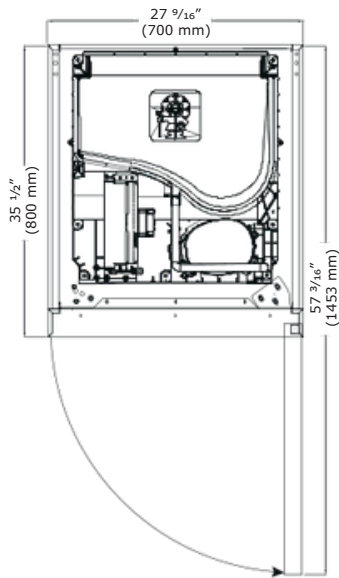

Side

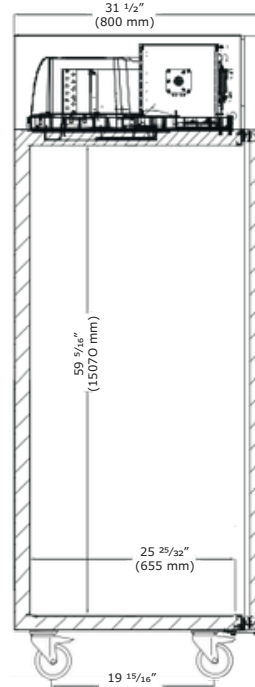

Commercial Warranty

3 Year (parts & labor) / 5 year sealed system (parts)

See complete warranty for details



25 cu ft Refrigerators, Reach-In

- Improve the flow and function of your space by having refrigerated items where you need them most
- Comfortably fits 18" x 26" sheet pans (not included)
- Glass & solid door options available
- 4 casters (2 locking) included to provide easy mobility
- LED lighting on glass door models



UCRE527-SS31A



UCRE527-SG41A

Model	Description	Voltage/Hz/Amps	Shipping Weight
UCRE527-SS31A	25 cu ft Refrigerator Solid Door, Reach-In, Field Reversible Hinge	115v / 60hz / 3.2	287 lb
UCRE527-SG41A	25 cu ft Refrigerator Glass Door, Reach-In, Right Hand Hinge	115v / 60hz / 3.2	327 lb

Specifications

UCRE527-SS31A dimensions: 82 9/32" H x 26 57/64" W x 31 1/2" D
UCRE527-SG41A dimensions: 82 9/32" H x 26 57/64" W x 31 1/2" D
AISI 304 stainless steel interior and exterior with lock
Autodefrost
CFC-free high density polyurethane insulated cabinet
Electronic digital temperature control with alarms
Environmentally friendly R290 refrigerant - 3.2 oz (0.090kg)
Epoxy coated, sealed evaporator eliminates potential of corrosion
Factory pre-wired for dedicated outlet, 11 ft cord and plug included NEMA 5-15P
High efficiency compressor, top mount
High efficiency evaporator coil & condenser
Includes 3 epoxy coated wire shelves
NSF/ANSI Standard 7 compliant
Temperature range: 28°F to 46°F
Volume of 25 cu ft

Accessories	Description	Shipping Weight
ULAQ32-0002	(1) Epoxy coated wire shelf, 20 7/8" x 25 5/8" for reach-ins	7 lb
ULA4080584	(1) Stainless steel shelf guide for all reach-ins except UCRE553 & UCFZ553, 24 3/4"	.88 lb
ULA80110300	Interior LED lighting kit for solid door reach-ins	2.2 lb

Front (Open)

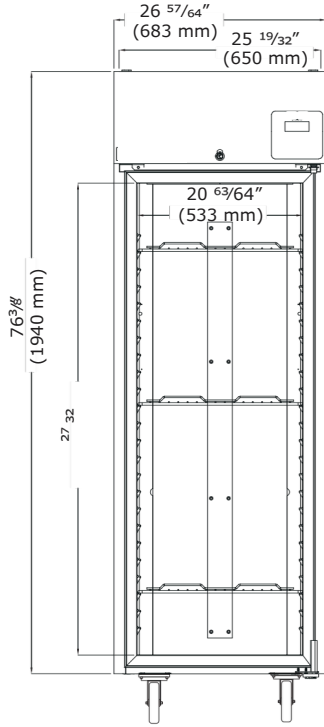

Side

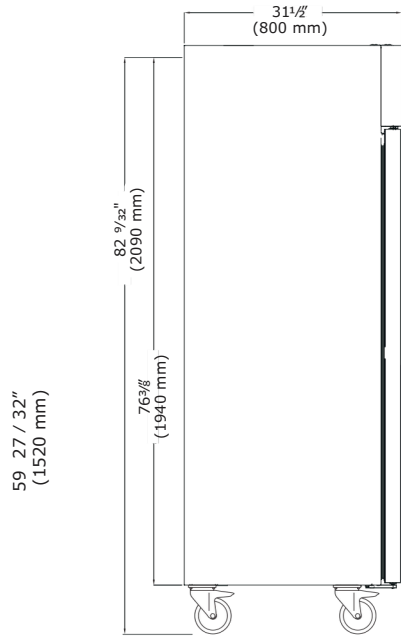

Front (Closed - Glass Door)

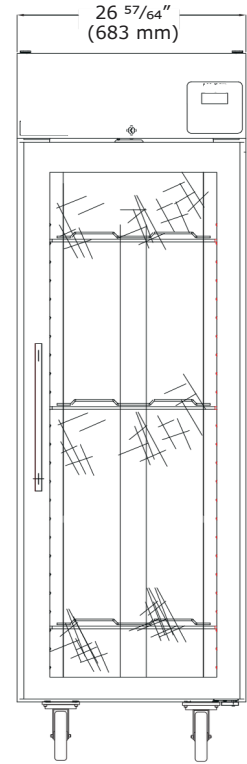

Top

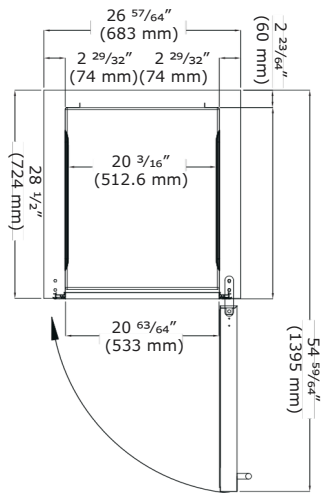

Side

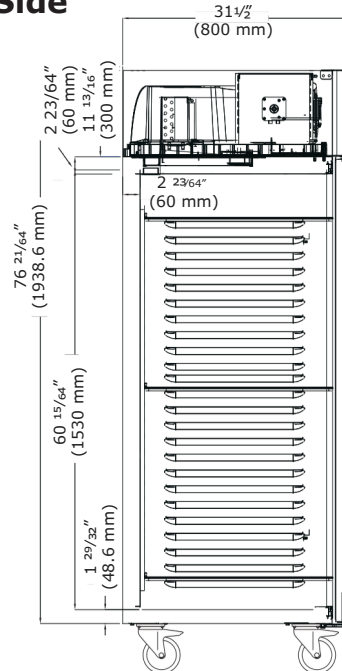

Commercial Warranty

3 Year (parts & labor) / 5 year sealed system (parts)

See complete warranty for details



49 cu ft Refrigerator, Reach-In

- Improve the flow and function of your space by having frozen items where you need them most
- Comfortably fits 18" x 26" sheet pans (not included)
- 4 casters included (2 locking) for easy mobility



UCRE455-SS71A

Model	Description	Voltage/Hz/Phase/Amps	Shipping Weight
UCRE455-SS71A	Freezer, Reach-In	115v / 60hz / 1 / 9.6	418 lb

Specifications

UCRE455-SS71A dimensions: 80 23/32" H x 55 1/8" W x 31 1/2" D
AISI 441 stainless steel interior and exterior with locks
Autodefrost
CFC-free high-density polyurethane insulated cabinet
Electronic digital temperature control with alarms
Environmentally friendly R290 refrigerant: 4.2 oz (0.120kg)
Factory pre-wired for dedicated outlet, 11 ft cord and plug included NEMA 5-15P
High efficiency compressor, top mount
High efficiency evaporator coil & condenser
NSF/ANSI Standard 7 compliant
Self-lubricating, sealed cast iron evaporator fan motor with high volume airflow design
Temperature range: 28°F to 46°F
Volume of 49 cu ft
2 sections, includes 6 epoxy coated wire shelves

Accessories	Description	Shipping Weight
ULA4080584	(1) Stainless steel shelf guide for all reach-ins except UCRE553 & UCFZ553, 24 3/4"	.88 lb
ULAQ32-0002	(1) Epoxy coated wire shelf, 20 7/8" x 25 5/8" for reach-ins	7 lb
ULA89030400	Stainless steel adjustable leg kit includes 5 legs, 4-5/8" H to 7-1/8" H, M8 bolts	11.02 lb
ULA80110300	Interior LED lighting kit for solid door reach-ins	2.2 lb

Front (Open)

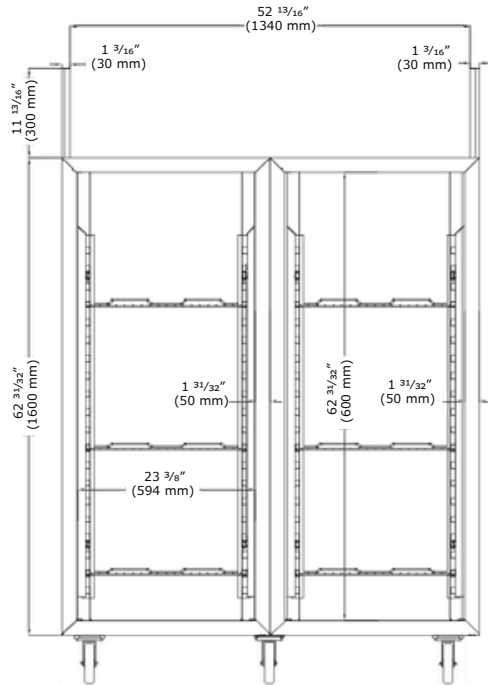

Front (Closed)

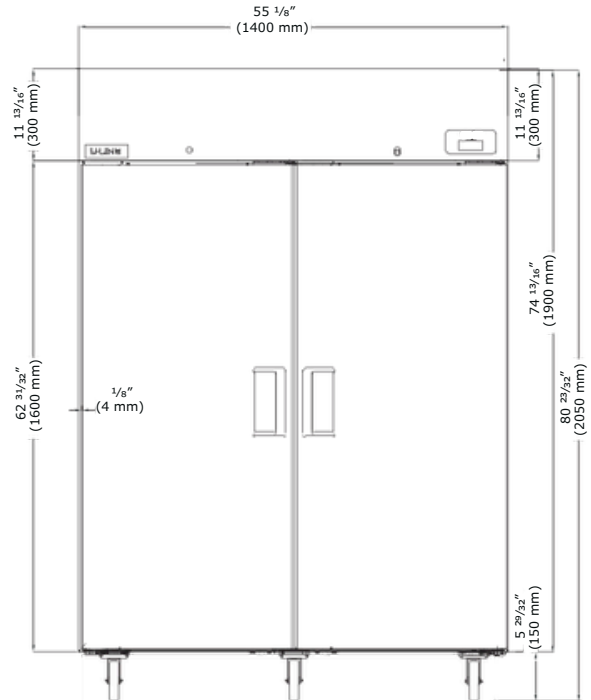

Top

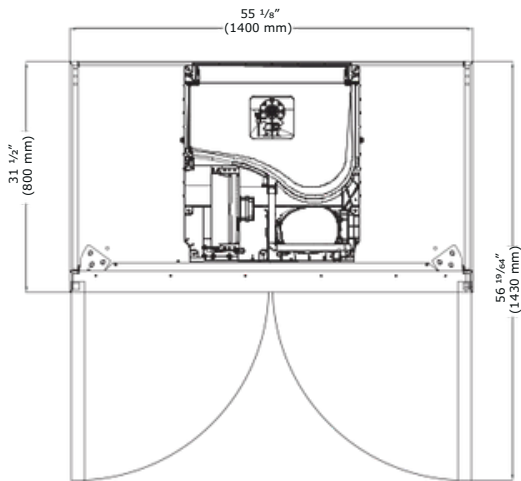

Side

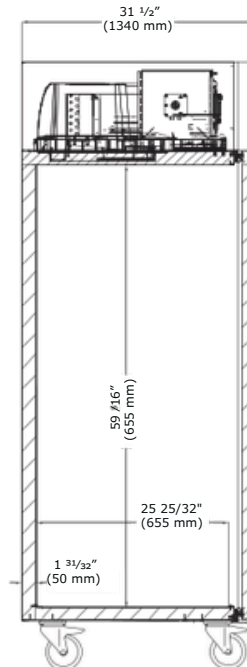

Commercial Warranty

3 Year (parts & labor) / 5 year sealed system (parts)

See complete warranty for details



49 cu ft Refrigerators, Reach-In

- Improve the flow and function of your space by having refrigerated items where you need them most
- Comfortably fits 18" x 26" sheet pans (not included)
- Glass & solid door options available
- 6 casters included (2 locking) for easy mobility
- LED lighting on glass door models



UCRE553-SS71A



UCRE553-SG71A

Model	Description	Voltage/Hz/Amps	Shipping Weight
UCRE553-SS71A	49 cu ft Refrigerator, Reach-In, Solid Door	115v / 60hz / 5.4	419 lb
UCRE553-SG71A	49 cu ft Refrigerator, Reach-In, Glass Door	115v / 60hz / 5.4	518 lb

Specifications

UCRE553-SS71A dimensions: 82 9/32" H x 52 9/16" W x 31 1/2" D
UCRE553-SG71A dimensions: 82 9/32" H x 52 9/16" W x 31 1/2" D
AISI 304 stainless steel interior and exterior with locks
Autodefrost
CFC-free high density polyurethane insulated cabinet
Electronic digital temperature control with alarms
Environmentally friendly R290 refrigerant - 3.5 oz (0.100 kg)
Epoxy coated, sealed evaporator eliminates potential corrosion
Factory pre-wired for dedicated outlet, 11 ft cord and plug included NEMA 5-15P
High efficiency evaporator coil & condenser
High efficiency top-mounted compressor
NSF/ANSI Standard 7 compliant
Temperature range: 28°F to 46°F
Volume of 49 cu ft
2 sections, includes 6 epoxy coated wire shelves

Accessories	Description	Shipping Weight
ULA4080534	(1) Stainless steel embossed shelf guide for UCRE553 & UCFZ553 reach-ins, 22"	.88 lb
ULAQ32-0002	(1) Epoxy coated wire shelf, 20 7/8" x 25 5/8" for reach-ins	7 lb
ULA80110300	Interior LED lighting kit for solid door reach-ins	2.2 lb

**Front
 (Closed - Solid Door)**

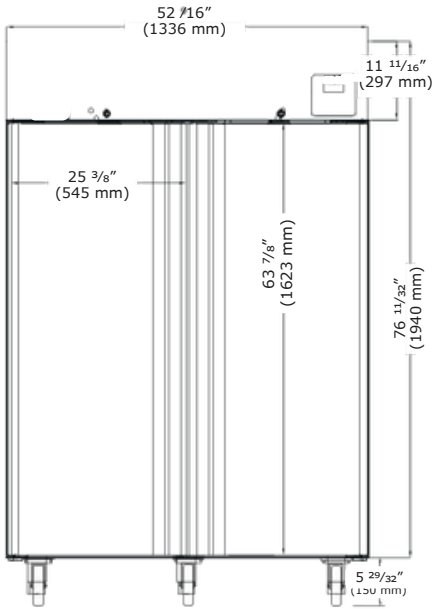

**Front
 (Closed - Glass Door)**

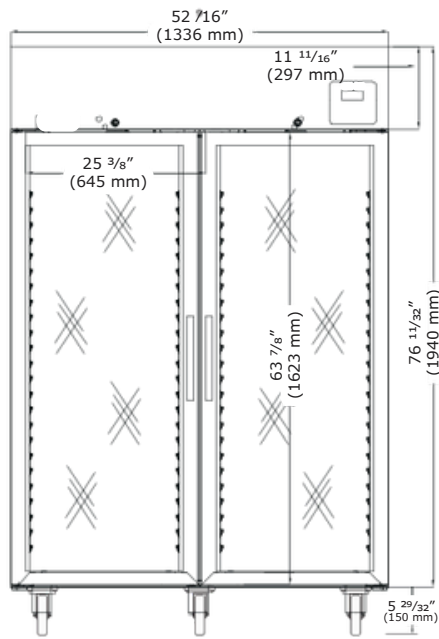

Side

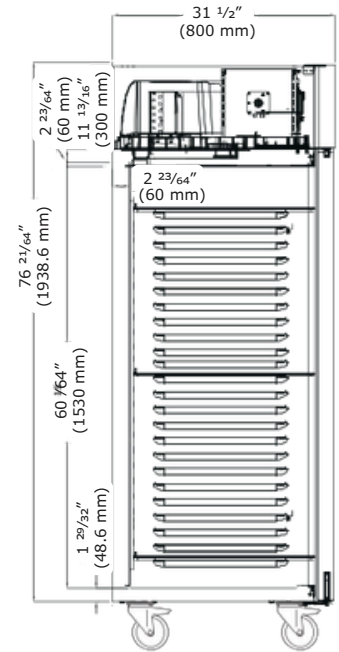

Top

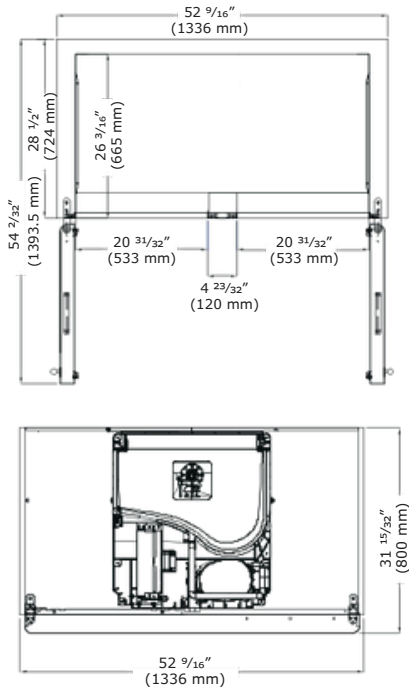

Back

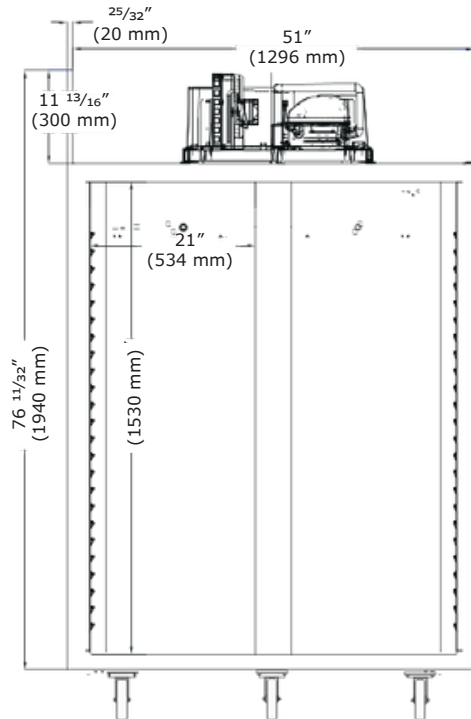

Side

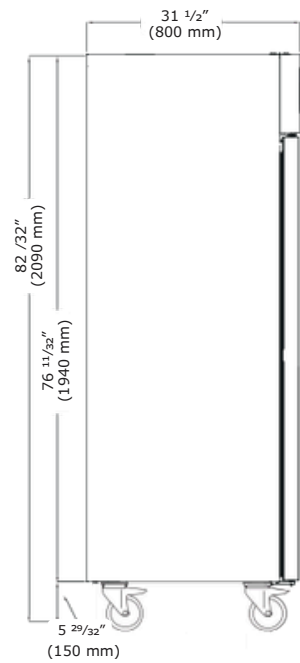

Commercial Warranty

3 Year (parts & labor) / 5 year sealed system (parts)

See complete warranty for details



74 cu ft Refrigerators, Reach-In

- Improve the flow and function of your space by having refrigerated items where you need them most
- Comfortably fits 18" x 26" sheet pans (not included)
- Glass & solid door options available
- 8 casters included (2 locking) for easy mobility
- LED lighting on glass door models



UCRE585-SS71A



UCRE585-SG71A

Model	Description	Voltage/Hz/Amps	Shipping Weight
UCRE585-SS71A	Refrigerator, Reach-In, Solid Door	115v / 60hz / 7	650 lb
UCRE585-SG71A	Refrigerator, Reach-In, Glass Door	115v / 60hz / 7	750 lb

Specifications

UCRE585-SS71A dimensions: 83 15/32" H x 85 3/64" W x 31 15/32" D
UCRE585-SG71A dimensions: 83 15/32" H x 85 3/64" W x 31 15/32" D
AISI 304 stainless steel interior and exterior with locks
Autodefroster
CFC-free high density polyurethane insulated cabinet
Electronic digital temperature control with alarms
Environmentally friendly R290 refrigerant: 2 x 3.2 oz (2 x 0.090 kg)
Epoxy coated, sealed evaporator eliminates potential corrosion
Factory pre-wired for dedicated outlet, 11 ft cord and plug included NEMA 5-15P
High efficiency evaporator coil & condenser
High efficiency top-mounted compressor
NSF/ANSI Standard 7 compliant
Temperature range: 28°F to 46°F
Volume of 74 cu ft
3 sections, includes 9 epoxy coated wire shelves

Accessories	Description	Shipping Weight
ULA4080584	(1) Stainless steel shelf guide for all reach-ins except UCRE553 & UCFZ553, 24 3/4"	.88 lb
ULAQ32-0002	(1) Epoxy coated wire shelf, 20 7/8" x 25 5/8" for reach-ins	7 lb
ULA80110300	Interior LED lighting kit for solid door reach-ins	2.2 lb

Front (Closed - Solid Door)

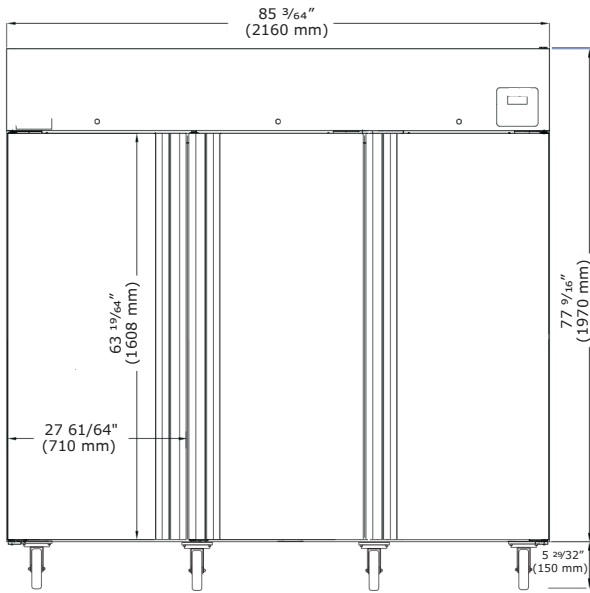

Front (Open)

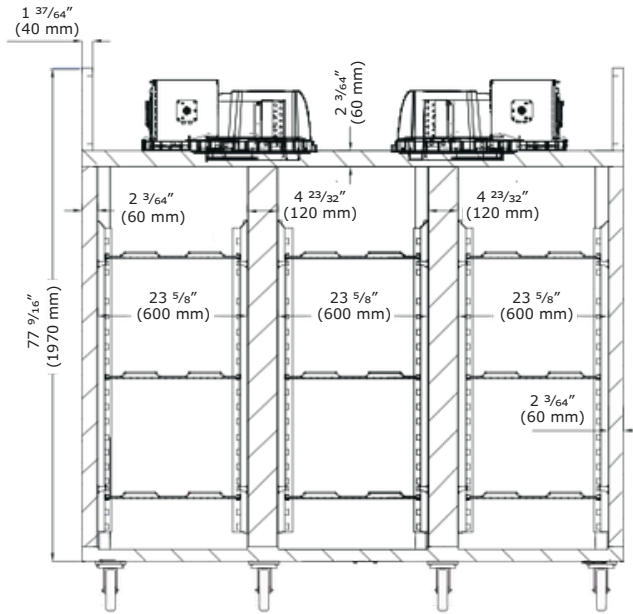

Front (Closed - Glass Door)

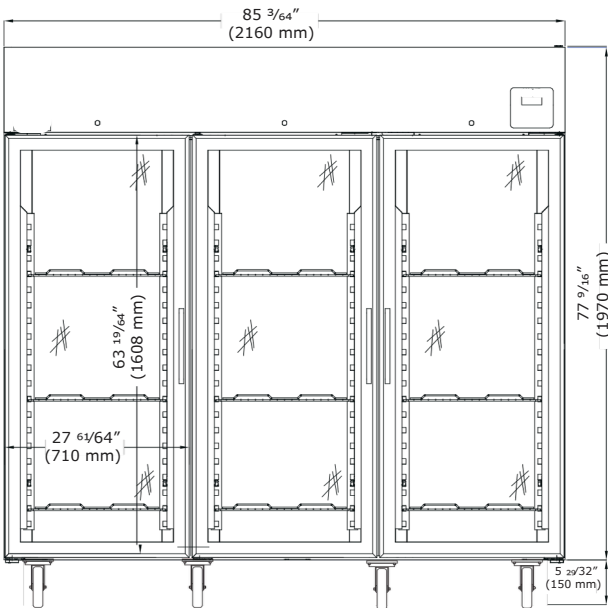

Side

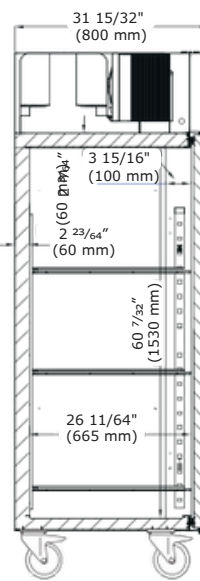

Top

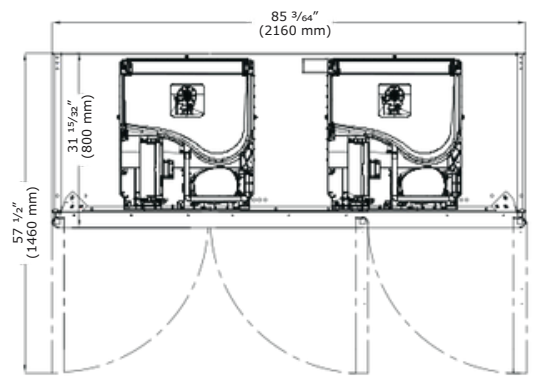

Commercial Warranty

3 Year (parts & labor) / 5 year sealed system (parts)

See complete warranty for details



25 cu ft Freezer, Reach-In

- Improve the flow and function of your space by having frozen items where you need them most
- Comfortably fits 18" x 26" sheet pans (not included)
- 4 casters included (2 locking) for easy mobility



UCFZ427-SS01A

Model	Description	Voltage/Hz/Phase/Amps	Shipping Weight
UCFZ427-SS01A	25 cu ft Freezer, Reach-In, Field Reversible Hinge	115v / 60hz / 1 / 6.2	287 lb

Specifications

UCFZ427-SS01A dimensions: 80 23/32" H x 27 9/16" W x 31 1/2" D
AISI 441 stainless steel interior and exterior with lock
Autodefrost
CFC-free high-density polyurethane insulated cabinet
Electronic digital temperature control with alarms
Environmentally friendly R290 refrigerant: 3.9 oz (0.110 kg)
Factory pre-wired for dedicated outlet, 11 ft cord and plug included NEMA 5-15P
High efficiency compressor, top mount
High efficiency evaporator coil & condenser
NSF/ANSI Standard 7 compliant
Self-lubricating, sealed cast iron evaporator fan motor with high volume airflow design
Temperature range: -13°F to 14°F
Volume of 25 cu ft
1 section, includes 3 epoxy coated wire shelves

Accessories	Description	Shipping Weight
ULA4080584	(1) Stainless steel shelf guide for all reach-ins except UCRE553 & UCFZ553, 24 3/4"	.88 lb
ULAQ32-0002	(1) Epoxy coated wire shelf, 20 7/8" x 25 5/8" for reach-ins	7 lb
ULA89020410	Stainless steel adjustable leg kit includes 4 legs, 4 5/8" H to 7 1/8" H, M6 bolts	11.02 lb
ULA80110300	Interior LED lighting kit for solid door reach-ins	2.2 lb

Front (Open)

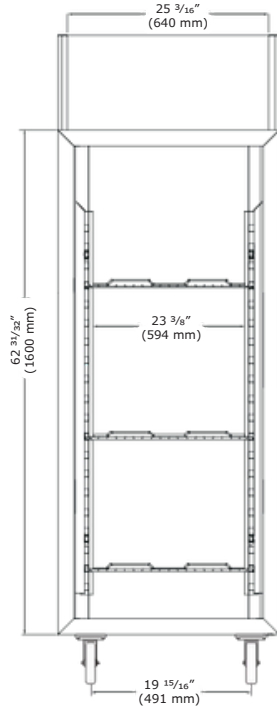

Front (Closed)

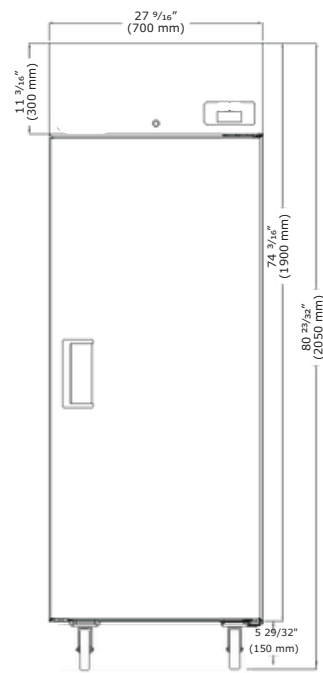

Top

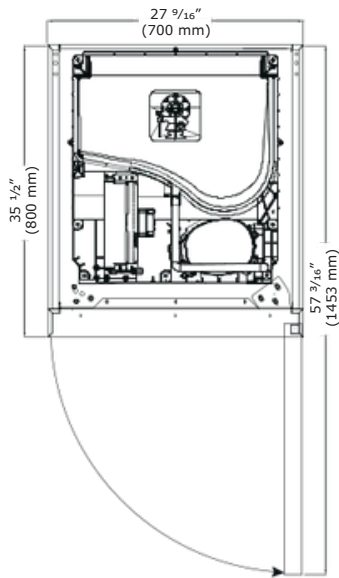

Side

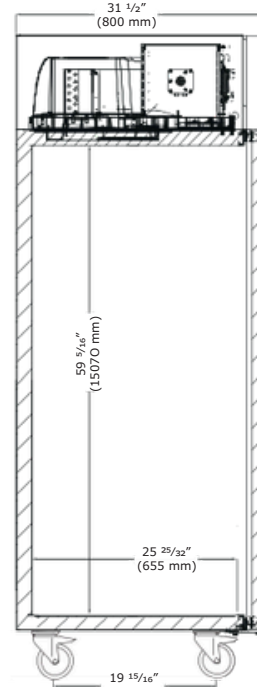

Commercial Warranty

3 Year (parts & labor) / 5 year sealed system (parts)

See complete warranty for details



25 cu ft Freezers, Reach-In

- Improve the flow and function of your space by having frozen items where you need them most
- Comfortably fits 18" x 26" sheet pans (not included)
- 4 casters included (2 locking) for easy mobility
- LED lighting on glass door models



UCFZ527-SS31A



UCFZ527-SG31A

Model	Description	Voltage/Hz/Amps	Shipping Weight
UCFZ527-SS31A	25 cu ft Freezer Solid Door, Reach-In, Field Reversible Hinge	115v / 60hz / 6.2	297 lb
UCFZ527-SG31A	25 cu ft Freezer Glass Door, Reach-In, Field Reversible Hinge	115v / 60hz / 6.2	353 lb

Specifications

UCFZ527-SS31A dimensions: 82 9/32" H x 26 57/64" W x 31 1/2" D
UCFZ527-SG31A dimensions: 82 9/32" H x 26 57/64" W x 31 1/2" D
AISI 304 Stainless steel interior and exterior with lock
Autodefrost
CFC-free high-density polyurethane insulated cabinet
Environmentally friendly R290 refrigerant: 3.9 oz (0.110 kg)
Electronic digital temperature control with alarms
Factory pre-wired for dedicated outlet, 11 ft. cord and plug included NEMA 5-15P
High efficiency evaporator coil & condenser
High efficiency top-mounted compressor
NSF/ANSI Standard 7 compliant
Removable magnetic gasket for easy cleaning
Self-lubricating, sealed cast iron evaporator fan motor with high volume air flow design
Temperature range: -13°F to 14°F
Volume of 25 cu ft
1 section, includes 3 epoxy coated wire shelves

Accessories	Description	Shipping Weight
ULAQ32-0002	(1) Epoxy coated wire shelf, 20 7/8" x 25 5/8" for reach-ins	7 lb
ULA4080584	(1) Stainless steel shelf guide for all reach-ins except UCRES553 & UCFZ553, 24 3/4"	.88 lb
ULA80110300	Interior LED lighting kit for solid door reach-ins	2.2 lb

Front (Open)

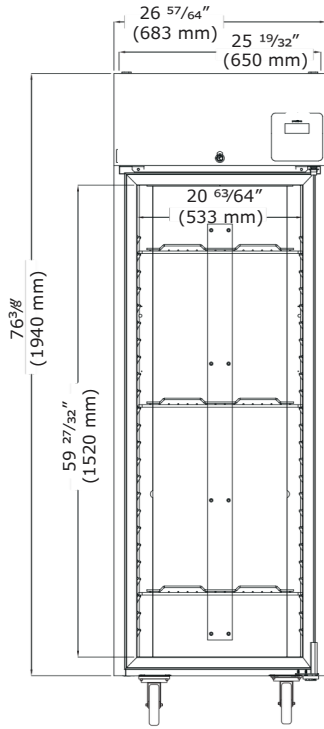

Side

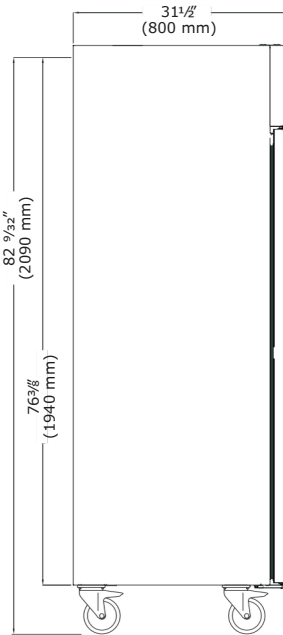

Front (Closed - Glass Door)

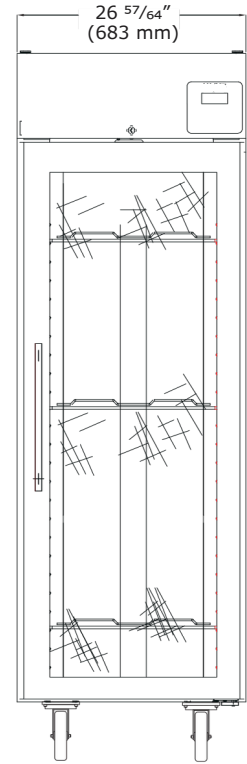

Top

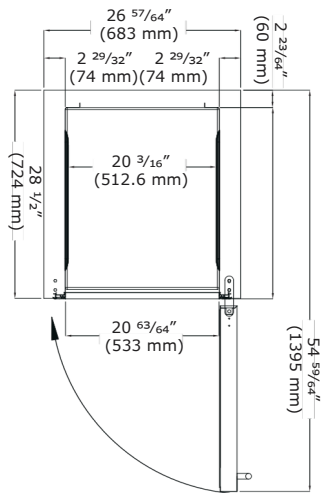

Side

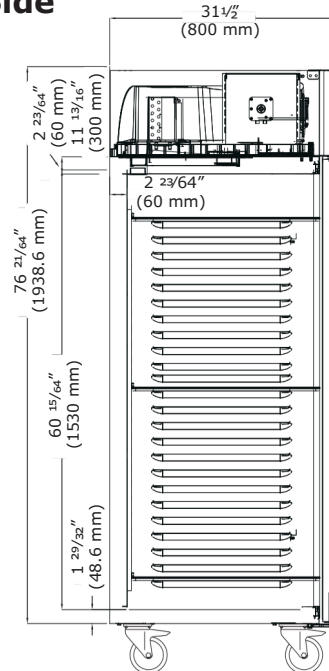

Commercial Warranty

3 Year (parts & labor) / 5 year sealed system (parts)

See complete warranty for details



49 cu ft Freezer, Reach-In

- Improve the flow and function of your space by having frozen items where you need them most
- Comfortably fits 18" x 26" sheet pans (not included)
- 4 casters included (2 locking) for easy mobility



UCFZ455-SS71A

Model	Description	Voltage/Hz/Phase/Amps.	Shipping Weight
UCFZ455-SS71A	Freezer, Reach-In	115v / 60hz / 1 / 9.6	418 lb

Specifications

UCFZ455-SS71A dimensions: 80 23/32" H x 55 1/8" W x 31 1/2" D
AISI 441 stainless steel interior and exterior with locks
Autodefrost
CFC-free high-density polyurethane insulated cabinet
Electronic digital temperature control with alarms
Environmentally friendly R290 refrigerant: 4.2 oz (0.120kg)
Factory pre-wired for dedicated outlet, 11 ft cord and plug included NEMA 5-15P
High efficiency compressor, top mount
High efficiency evaporator coil & condenser
NSF/ANSI Standard 7 compliant
Self-lubricating, sealed cast iron evaporator fan motor with high volume airflow design
Temperature range: -13°F to 14°F
Volume of 49 cu ft
2 sections, includes 6 epoxy coated wire shelves

Accessories	Description	Shipping Weight
ULA4080584	(1) Stainless steel shelf guide for all reach-ins except UCRE553 & UCFZ553, 24 3/4"	.88 lb
ULAQ32-0002	(1) Epoxy coated wire shelf, 20 7/8" x 25 5/8" for reach-ins	7 lb
ULA89030400	Stainless steel adjustable leg kit includes 5 legs, 4-5/8" H to 7-1/8" H, M8 bolts	11.02 lb
ULA80110300	Interior LED lighting kit for solid door reach-ins	2.2 lb

Front (Open)

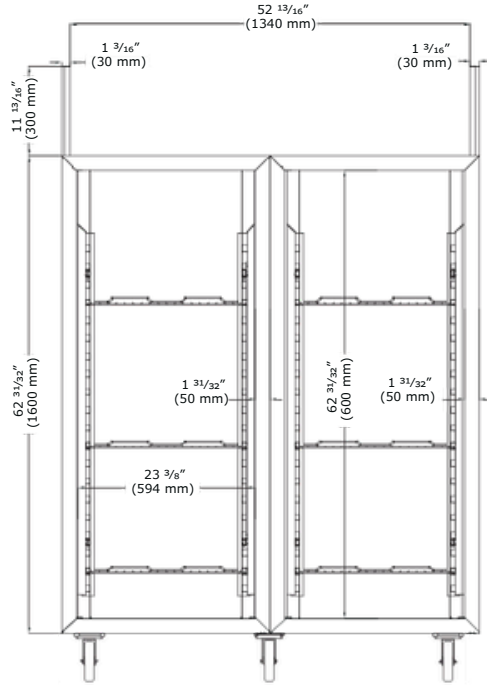

Front (Closed)

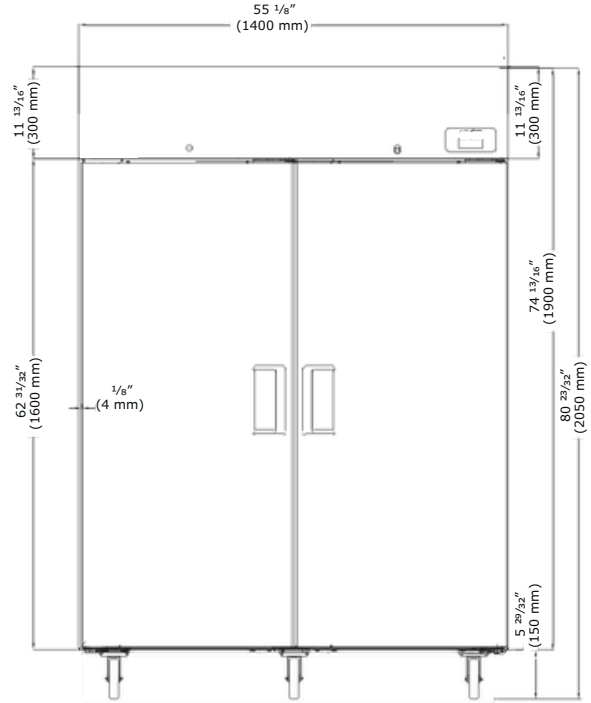

Top

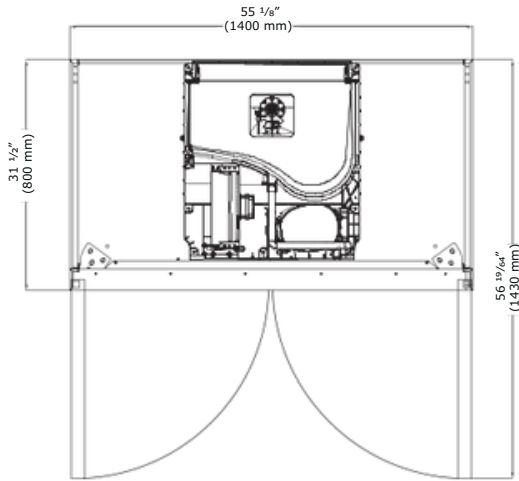

Side

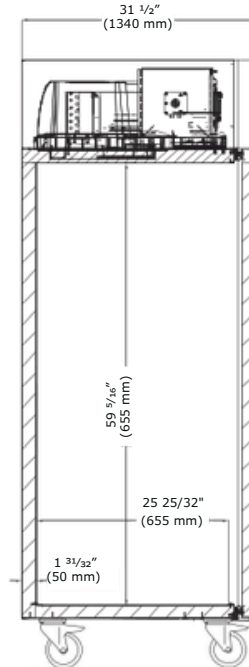

Commercial Warranty

3 Year (parts & labor) / 5 year sealed system (parts)

See complete warranty for details



49 cu ft Freezers, Reach-In

- Improve the flow and function of your space by having frozen items where you need them most
- Comfortably fits 18" x 26" sheet pans (not included)
- Glass & solid door options
- 6 casters included (2 locking) for easy mobility
- LED lighting on glass door models



UCFZ553-SS71A



UCFZ553-SG71A

Model	Description	Voltage/Hz/Amps	Shipping Weight
UCFZ553-SS71A	49 cu ft Freezer Solid Door, Reach-In	115v / 60hz / 9.6	441 lb
UCFZ553-SG71A	49 cu ft Freezer Glass Door, Reach-In	115v / 60hz / 9.6	617 lb

Specifications

UCFZ553-SS71A dimensions: 82 9/32" H x 52 9/16" W x 31 1/2" D
UCFZ553-SG71A dimensions: 82 9/32" H x 52 9/16" W x 31 1/2" D
AISI 304 Stainless steel interior and exterior with locks
Autodefrost
CFC-free high-density polyurethane insulated cabinet
Electronic digital temperature control with alarms
Environmentally friendly R290 refrigerant - 4.2 oz (0.120kg)
Factory pre-wired for dedicated outlet, 11 ft cord and plug included NEMA 5-15P
High efficiency evaporator coil & condenser
High efficiency top-mounted compressor with 9.6 running amps
LED lighting
NSF/ANSI Standard 7 compliant
Removable magnetic gasket for easy cleaning
Self-lubricating, sealed cast iron evaporator fan motor with high volume air flow design
Temperature range: -13°F to 14°F
Volume of 49 cu ft
2 sections, includes 6 epoxy coated wire shelves

Accessories	Description	Shipping Weight
ULA4080534	(1) Stainless steel embossed shelf guide for UCRE553 & UCFZ553 reach-ins, 22"	.88 lb
ULAQ32-0002	(1) Epoxy coated wire shelf, 20 7/8" x 25 5/8" for reach-ins	7 lb
ULA80110300	Interior LED lighting kit for solid door reach-ins	2.2 lb

**Front
(Closed - Solid Door)**

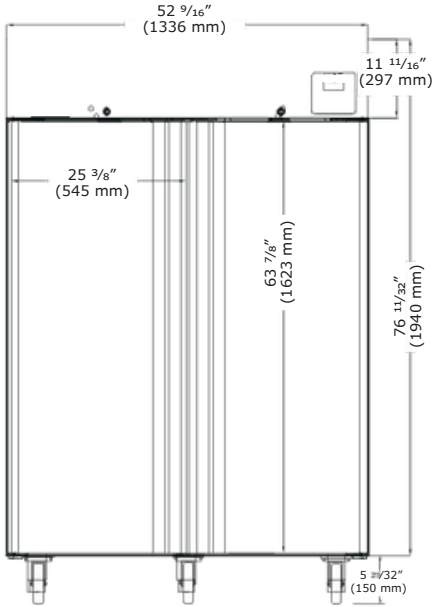

**Front
(Closed - Glass Door)**

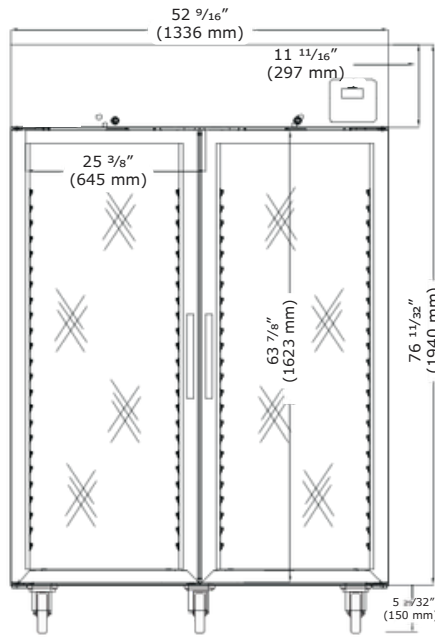

Side

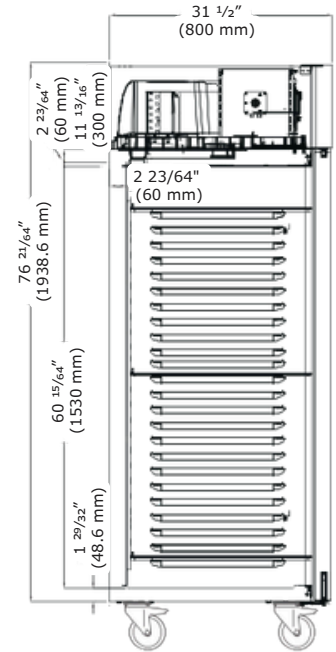

Top

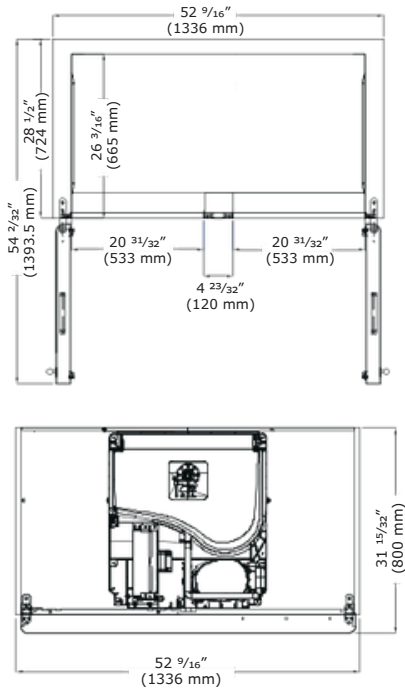

Back

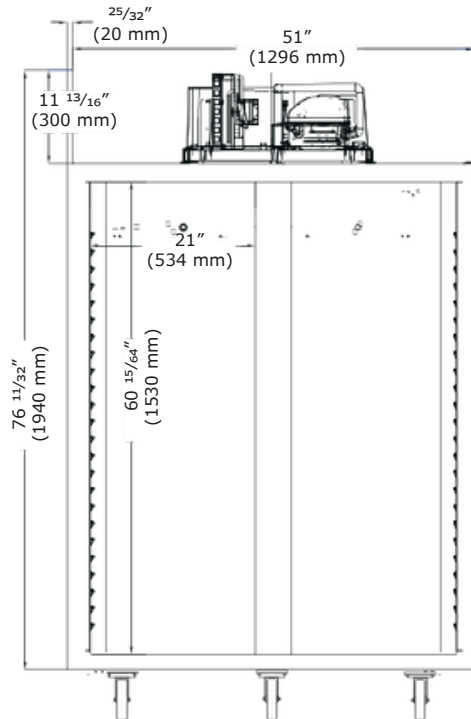

Side

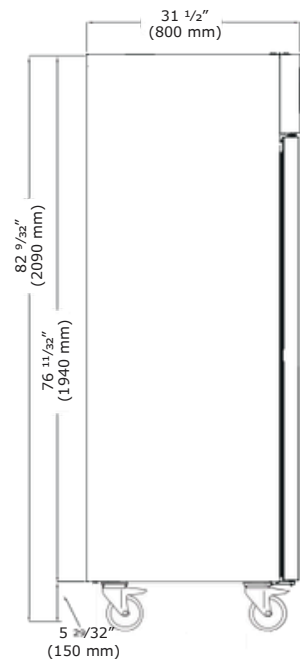

Commercial Warranty

3 Year (parts & labor) / 5 year sealed system (parts)

See complete warranty for details



74 cu ft Freezers, Reach-In

- Improve the flow and function of your space by having frozen items where you need them most
- Comfortably fits 18" x 26" sheet pans (not included)
- Glass & solid door options
- 8 casters included (2 locking) for easy mobility
- LED lighting on glass door models



UCFZ585-SS71A



UCFZ585-SG71A

Model	Description	Voltage/Hz/Amps	Shipping Weight
UCFZ585-SS71A	Freezer, Reach-In, Solid Door	115v / 60hz / 20	650 lb
UCFZ585-SG71A	Freezer, Reach-In, Glass Door	115v / 60hz / 20	750 lb

Specifications

UCFZ585 dimensions: 83 15/32" H x 85 3/64" W x 31 15/32" D
AISI 304 stainless steel interior and exterior with locks
Autodefrost
CFC-free high-density polyurethane insulated cabinet
Electronic digital temperature control with alarms
Environmentally friendly R290 refrigerant: 2 x 3.5 oz (2 x 0.100kg)
Factory pre-wired for dedicated outlet, 11 ft. cord and plug included NEMA 5-20P
High efficiency compressor
High efficiency evaporator coil & condenser
NSF/ANSI Standard 7 compliant
Removable magnetic gasket for easy cleaning
Self-lubricating, sealed cast iron evaporator fan motor with high volume air flow design
Temperature range: -13°F to 14°F
Volume of 74 cu ft
3 sections, includes 9 epoxy coated wire shelves

Accessories	Description	Shipping Weight
ULA4080584	(1) Stainless steel shelf guide for all reach-ins except UCRE553 & UCFZ553, 24 3/4"	.88 lb
ULAQ32-0002	(1) Epoxy coated wire shelf, 20 7/8" x 25 5/8" for reach-ins	7 lb
ULA80110300	Interior LED lighting kit for solid door reach-ins	2.2 lb

Front (Closed - Solid Door)

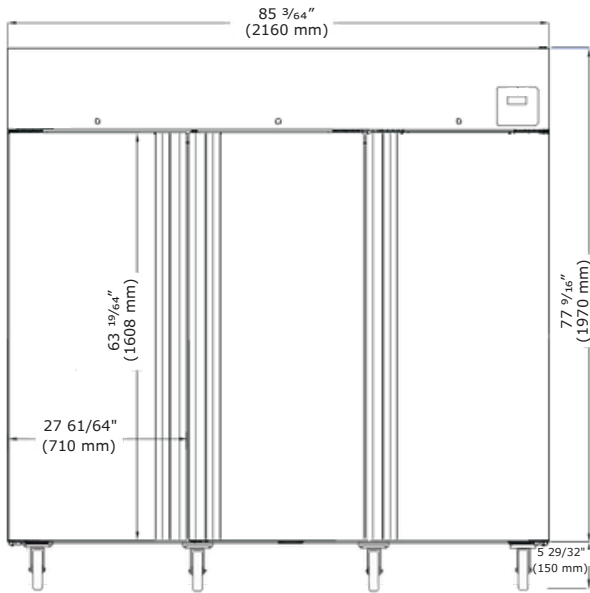

Front (Open)

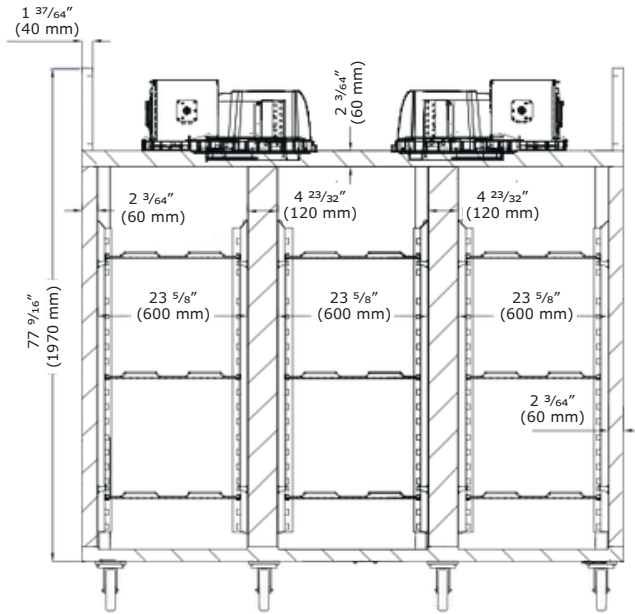

Front (Closed - Glass Door)

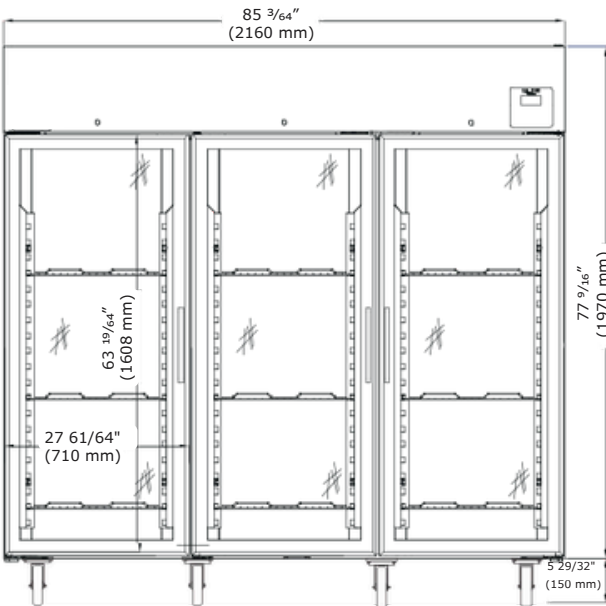

Side

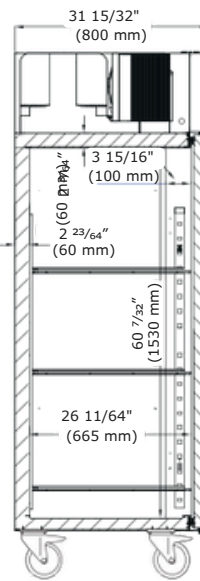

Top

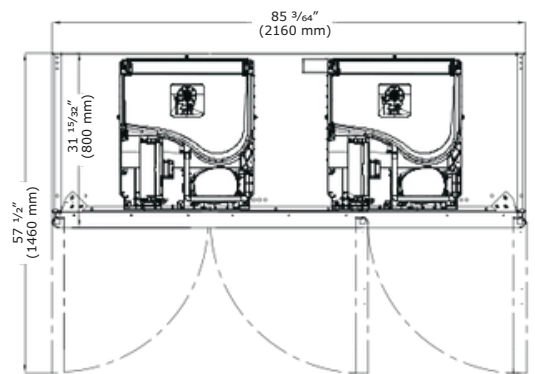

Commercial Warranty

3 Year (parts & labor) / 5 year sealed system (parts)

See complete warranty for details





Refrigerator & Freezer Bases

REFRIGERATION SOLUTIONS

Our refrigerator and freezer chef bases are perfect for kitchens seeking to optimize space utilization while maintaining an efficient workflow. These versatile appliances provide chefs and kitchen staff convenient drawer access designed to store trays of chilled or frozen ingredients. With included stacking capabilities, QualServ chef bases allow you to maximize vertical space, allowing for additional appliances or tools to be stored above, creating the ultimate chef station.

Offered in a variety of sizes, these practical chef bases are ideal for even the smallest of spaces. Sturdy casters provide easy movement for an easy-to-clean environment and their robust construction and stainless steel components are built to withstand the rigors of daily use. These reliable refrigeration and freezer solutions deliver functionality where you need it most.

Refrigerator Chef Bases

- Create the ultimate chef station by stacking additional equipment on top, from grills to ovens and more
- Our trusted chef bases give staff the confidence of keeping ingredients fresh
- Casters (2 locking) included for easy mobility



Model	Description	Cooled Volume	Voltage/Hz/Phase/Amps	Shipping Weight
UCRB536-SS61A	36" Refrigerator Chef Base	4 cu ft	115v / 60hz / 1 / 7.3	340 lb
UCRB548-SS61A	48" Refrigerator Chef Base	6.7 cu ft	115v / 60hz / 1 / 7.3	410 lb
UCRB560-SS61A	60" Refrigerator Chef Base	10 cu ft	115v / 60hz / 1 / 7.3	549 lb
UCRB572-SS61A	72" Refrigerator Chef Base	13 cu ft	115v / 60hz / 1 / 8.7	653 lb

Specifications

UCRB536-SS61A dimensions: 26" H x 36" W x 32 1/2" D

UCRB548-SS61A dimensions: 26" H x 48" W x 32 1/2" D

UCRB560-SS61A dimensions: 26" H x 60" W x 32 1/2" D

UCRB572-SS61A dimensions: 26" H x 72" W x 32 1/2" D

UCRB536-SS61A: 2 drawers holds (2) standard size GN1/1 (12"x20"x4") pans (not included), top holds a static weight of 847 lb

UCRB548-SS61A: 2 drawers holds (4) standard size GN1/1 (12"x20"x4") pans (not included), top holds a static weight of 1508 lb

UCRB560-SS61A: 2 drawers holds (4) standard size GN1/1 (12"x20"x4") pans (not included), top holds a static weight of 1482 lb

UCRB572-SS61A: 4 drawers holds (8) standard size GN1/1 (12"x20"x4") pans (not included), top holds a static weight of 1411 lb

AISI 304 stainless steel interior and exterior

Autodefrost

CFC-free high-density polyurethane insulated cabinet

Electronic digital temperature control with alarms

Environmentally friendly R449a refrigerant - 16 oz (0.450 kg)

Factory pre-wired for dedicated outlet, 11 ft cord and plug included NEMA 5-15P

High efficiency compressor, side mount

High efficiency evaporator coil & condenser

NSF/ANSI Standard 7 compliant

Self-lubricating, sealed cast iron evaporator fan motor with high volume airflow design

Temperature range: 28°F to 46°F

Front (36" Model)

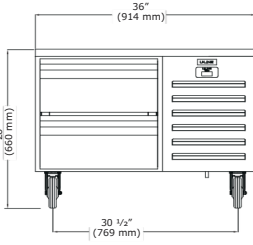

Side

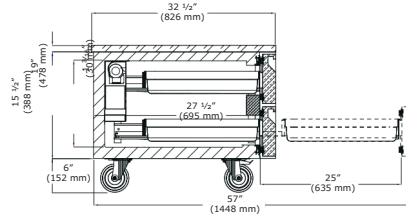

Top

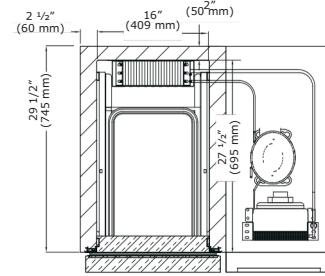

Front (48" Model)

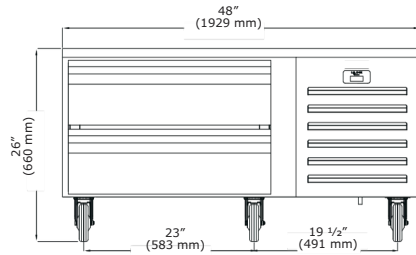

Side

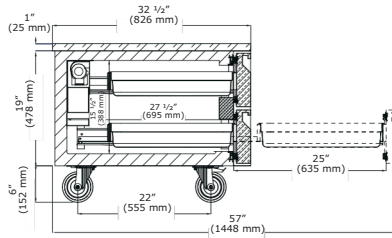

Top

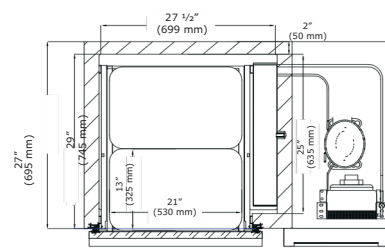

Front (60" Model)

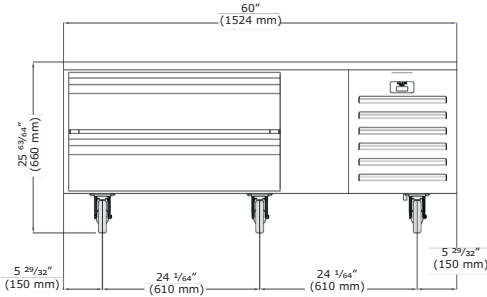

Side

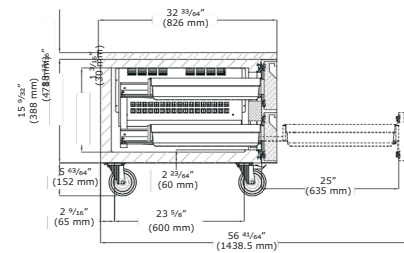

Top

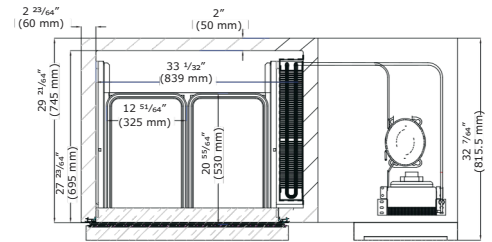

Front (72" Model)

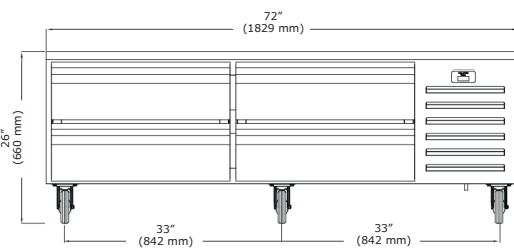

Side

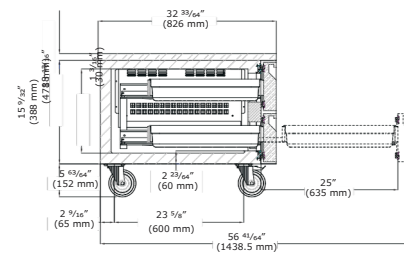

Top

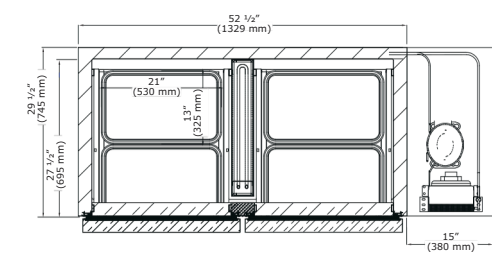

Commercial Warranty

3 Year (parts & labor) / 5 year sealed system (parts)

See complete warranty for details



QUALSERV® Product Specifications

Freezer Chef Bases

SOLUTIONS INTERNATIONAL

- Create the ultimate chef station by stacking additional equipment on top, from grills to ovens and more
- Our trusted chef bases give staff the confidence of keeping ingredients fresh
- 4 casters (2 locking) included for easy mobility



UCFB536-SS61A



UCFB548-SS61A



UCFB560-SS61A



UCFB572-SS61A

Model	Description	Cooled Volume	Voltage/Hz/Phase/Amps	Shipping Weight
UCFB536-SS61A	36" Freezer Chef Base	4 cu ft	115v / 60hz / 1 / 7.3	340 lb
UCFB548-SS61A	48" Freezer Chef Base	6.7 cu ft	115v / 60hz / 1 / 7.3	410 lb
UCFB560-SS61A	60" Freezer Chef Base	10 cu ft	115v / 60hz / 1 / 7.3	549 lb
UCFB572-SS61A	72" Freezer Chef Base	13 cu ft	115v / 60hz / 1 / 8.7	653 lb

Specifications

UCFB536-SS61A dimensions: 26" H x 36" W x 32 1/2" D

UCFB548-SS61A dimensions: 26" H x 48" W x 32 1/2" D

UCFB560-SS61A dimensions: 26" H x 60" W x 32 1/2" D

UCFB572-SS61A dimensions: 26" H x 72" W x 32 1/2" D

UCFB536-SS61A: 2 drawers holds (2) standard size GN1/1 (12"x20"x4") pans (not included), top holds a static weight of 847 lb

UCFB548-SS61A: 2 drawers holds (4) standard size GN1/1 (12"x20"x4") pans (not included), top holds a static weight of 1508 lb

UCFB560-SS61A: 2 drawers holds (4) standard size GN1/1 (12"x20"x4") pans (not included), top holds a static weight of 1482 lb

UCFB572-SS61A: 4 drawers holds (8) standard size GN1/1 (12"x20"x4") pans (not included), top holds a static weight of 1411 lb

AISI 304 stainless steel interior and exterior

Autodefrost

CFC-free high-density polyurethane insulated cabinet

Electronic digital temperature control with alarms

Environmentally friendly R449a refrigerant - 16 oz (0.450 kg)

Factory pre-wired for dedicated outlet, 11 ft cord and plug included

NEMA 5-15P High efficiency compressor, side mount

High efficiency evaporator coil & condenser

NSF/ANSI Standard 7 compliant

Self-lubricating, sealed cast iron evaporator fan motor with high volume airflow design

Temperature range: -13°F to 14°F

Front (36" Model)

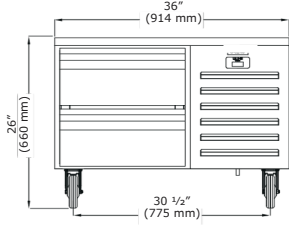

Side

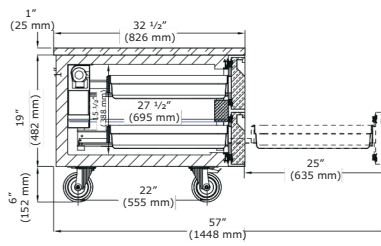

Top

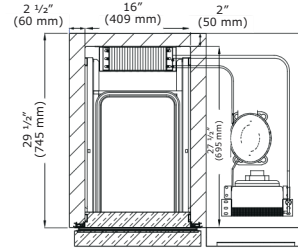

Front (48" Model)

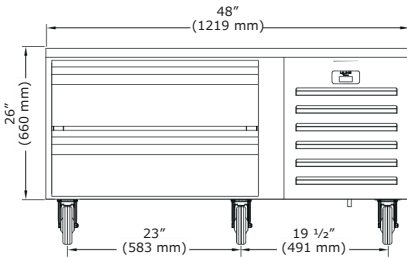

Side

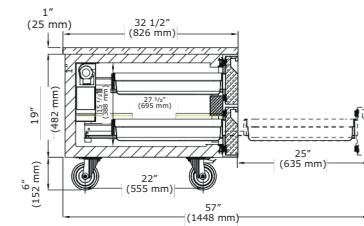

Top

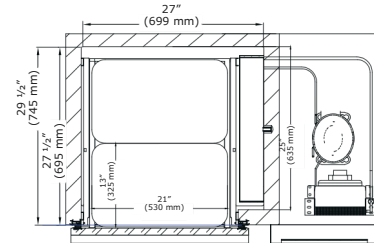

Front (60" Model)

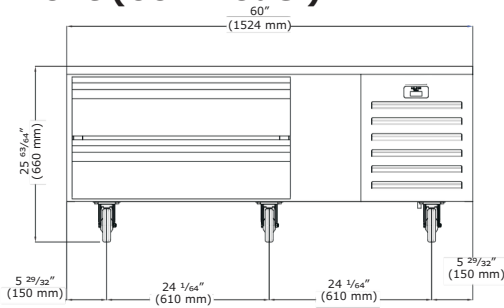

Side

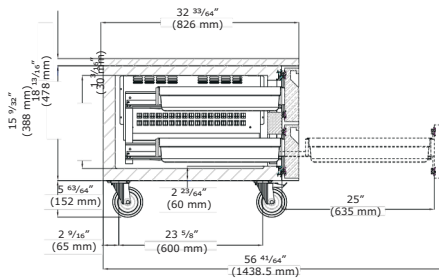

Top

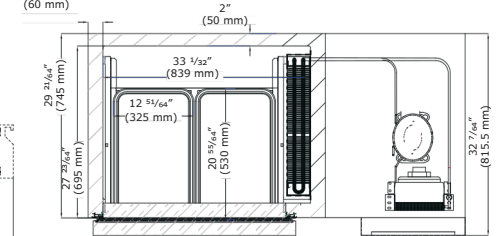

Front (72" Model)

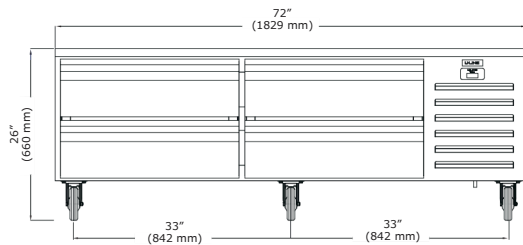

Side

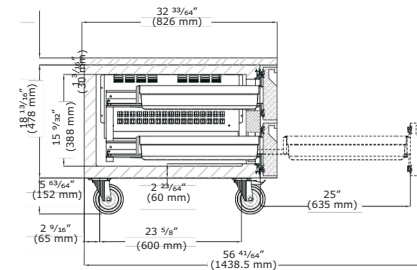

Top

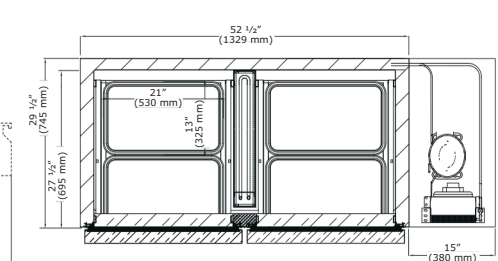

Commercial Warranty

3 Year (parts & labor) / 5 year sealed system (parts)

See complete warranty for details





Roll-In Refrigerators & Freezers

REFRIGERATION SOLUTIONS

QualServ commercial roll-in refrigerators and freezers offer unparalleled convenience for today's kitchens. These refrigerators and freezers are designed with large, accessible compartments that can accommodate racks of full-size sheet pans, allowing for easy loading and unloading of food items. Their roll-in design enables chefs and kitchen staff to effortlessly transport pre-prepped ingredients and cooked dishes directly into the refrigerators or freezers, minimizing handling and reducing the risk of contamination.

Engineered with durability and performance in mind, these appliances are perfect for the demanding conditions of bakeries, cafes, restaurants, and beyond. Constructed from high-quality materials, these products maintain precise temperatures, preserving the freshness and quality of stored items. With their combination of practical functionality, durability, and reliability, QualServ roll-in refrigerators and freezers are an asset to any kitchen or foodservice operation, improving efficiency and service.

Roll-In Refrigerators

- Improve the flow and function of your space by having refrigerated items where you need them most
- Solid door models
- Push carts directly into unit
- LED lighting



UCRE633-SS31A



UCRE666-SS71A

Model	Description	Voltage/Hz/Amps	Shipping Weight
UCRE633-SS31A	Roll-thru Refrigerator with Double Solid Door	115v / 60hz / 9.6	441 lb
UCRE666-SS71A	Roll-thru Refrigerator with Quadruple Solid Door	115v / 60hz / 19.2	639 lb

Specifications
UCRE633-SS31A dimensions: 88 1/2" H x 33 7/8" W x 45 1/2" D
UCRE666-SS71A dimensions: 88 1/2" H x 66 7/8" W x 45 1/2" D
UCRE633-SS31A: Environmentally friendly R290 refrigerant - 3.5 oz
UCRE666-SS71A: Environmentally friendly R290 refrigerant - 7.0 oz
UCRE633-SS31A: Factory pre-wired for dedicated outlet, 11 ft cord and plug included NEMA 5-15P
UCRE666-SS71A: Factory pre-wired for dedicated outlet, 11 ft cord and plug included NEMA 5-20P
UCRE633-SS31A volume: 35.8 cu ft
UCRE666-SS31A volume: 79 cu ft
AISI 304 stainless steel interior and exterior with lock
Autodefrost
CFC-free high density polyurethane insulated cabinet
Electronic digital temperature control with alarms
Epoxy coated, sealed evaporator eliminates potential of corrosion
Fixed stainless steel loading ramp
High efficiency compressor, top mount
High efficiency evaporator coil & condenser
NSF/ANSI Standard 7 compliant
Temperature range: 28°F to 46°F

Front UCRES633 (Open)

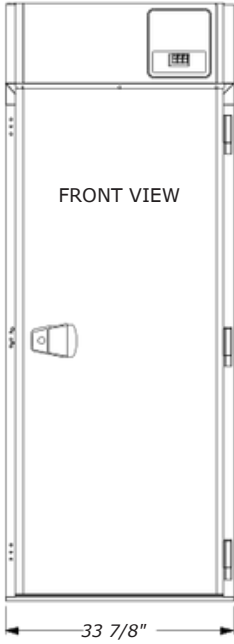

Front UCRES666 (Open)

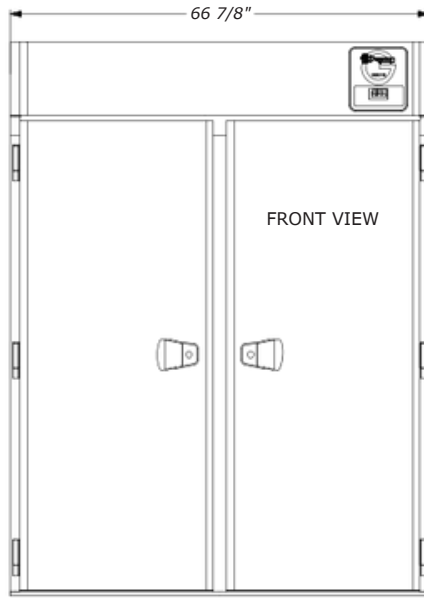

Side UCRES633/666

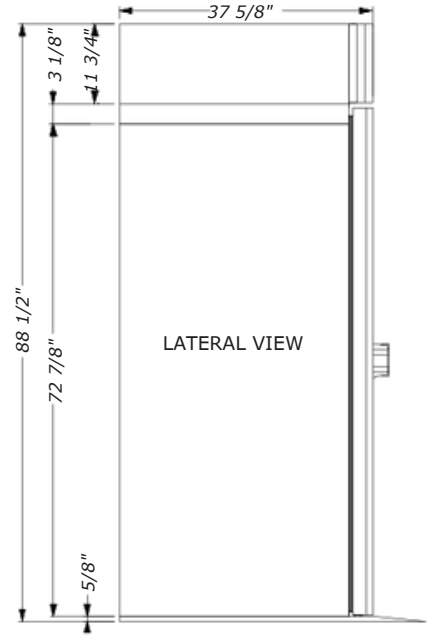

Top UCRES633

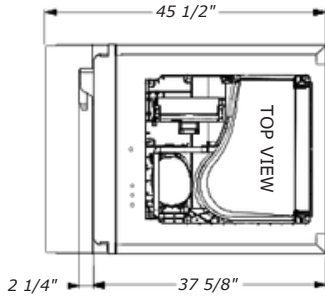

Top UCRES666

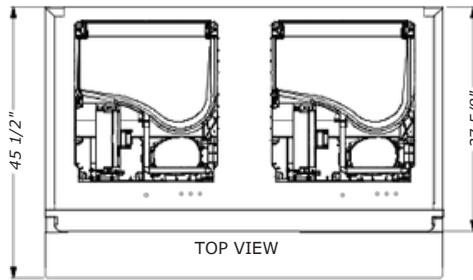

Back UCRES633/666

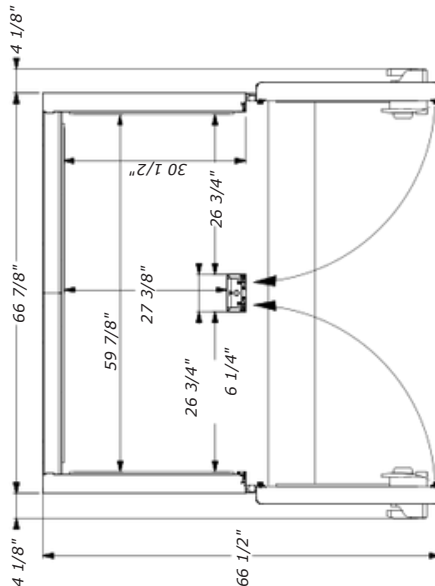
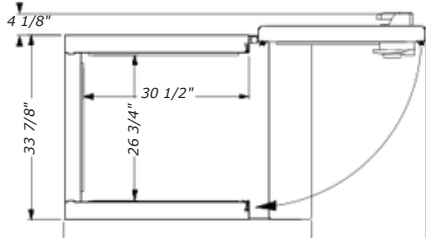
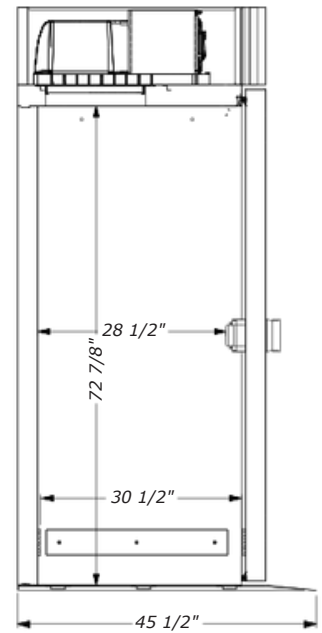

Commercial Warranty

3 Year (parts & labor) / 5 year sealed system (parts)
See complete warranty for details



Roll-In Freezers

- Improve the flow and function of your space by having frozen items where you need them most
- Solid door models
- Push carts directly into unit
- LED lighting



UCFZ633-SS31A



UCFZ666-SS71A

Model	Description	Voltage/Hz/Amps	Shipping Weight
UCFZ633-SS31A	Roll-in Freezer with Single Solid Door	115v / 60hz / 9.6	452 lb
UCFZ666-SS71A	Roll-in Freezer with Double Solid Door	115v / 60hz / 19.2	639 lb

Specifications

UCFZ633-SS31A dimensions: 89 3/4" H x 33 7/8" W x 46 1/2" D

UCFZ666-SS71A dimensions: 89 3/4" H x 66 7/8" W x 46 1/2" D

UCFZ633-SS31A: Environmentally friendly R290 refrigerant - 4.2 oz

UCFZ666-SS71A: Environmentally friendly R290 refrigerant - 8.2 oz

UCFZ633-SS31A: Factory pre-wired for dedicated outlet, 11 ft cord and plug included NEMA 5-15P

UCFZ666-SS71A: Factory pre-wired for dedicated outlet, 11 ft cord and plug included NEMA 5-20P

UCFZ633-SS31A volume: 35.8 cu ft

UCFZ666-SS71A volume: 79 cu ft

AISI 304 stainless steel interior and exterior with lock

Autodefrost

CFC-free high density polyurethane insulated cabinet

Electronic digital temperature control with alarms

Epoxy coated, sealed evaporator eliminates potential of corrosion

Fixed stainless steel loading ramp

High efficiency compressor, top mount

High efficiency evaporator coil & condenser

NSF/ANSI Standard 7 compliant

Temperature range: -13°F to 14°F

Front UCFZ633 (Open)

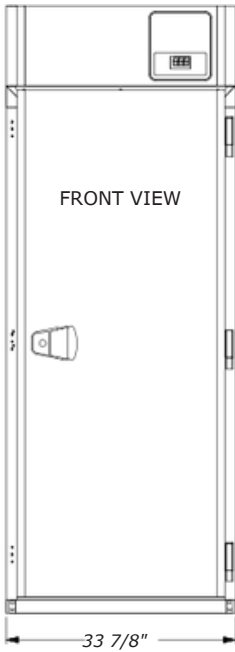

Front UCFZ666 (Open)

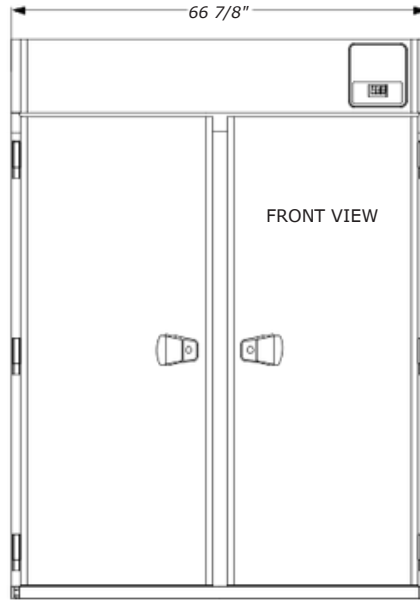

Side UCFZ633/666

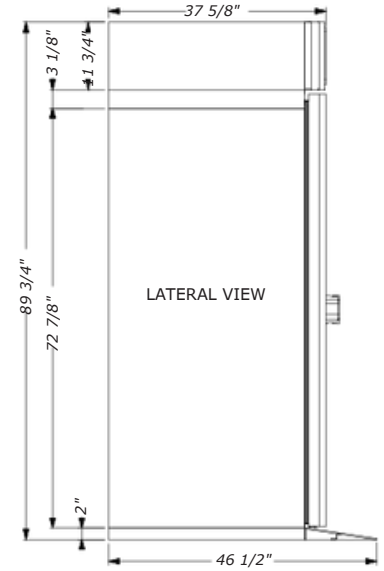

Top UCFZ633

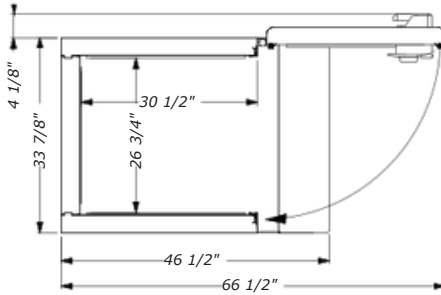

Top UCFZ666

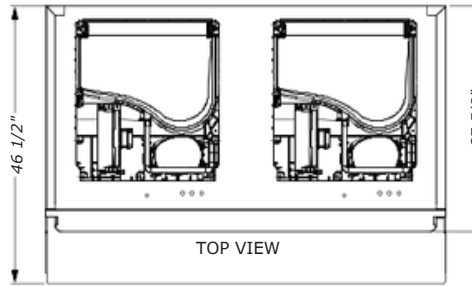

Back UCFZ633/666

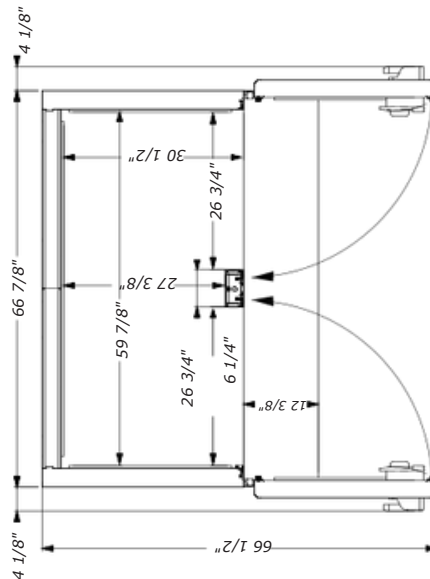
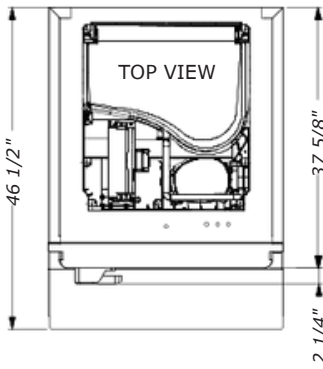
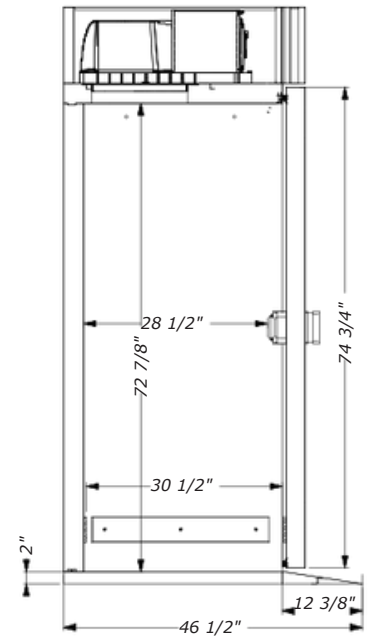

Commercial Warranty

3 Year (parts & labor) / 5 year sealed system (parts)
See complete warranty for details





Roll-Through Refrigerators

REFRIGERATION SOLUTIONS

QualServ commercial roll-through refrigerators provide cold storage, with kitchen flow in mind. These specialized refrigerators feature dual access points, allowing for seamless loading and unloading of food items from either side. This design facilitates a smooth workflow in busy kitchen environments, as ingredients can be quickly retrieved without disrupting food preparation processes. Our roll-through refrigerators are engineered for durability and performance, making them ideal for the demanding conditions of professional kitchens and cafeterias. Constructed from high-quality materials, these appliances maintain precise temperature control, preserving the freshness and quality of stored food items. Practical functionality, durability, and reliability are all key characteristics of QualServ's roll-through refrigerators and are ideal for any kitchen or cafeteria.

Roll-Thru Refrigerators

- Improve the flow and function of your space by having refrigerated items where you need them most
- Solid door models
- Push carts through the unit
- LED lighting



UCRE733-SS31A



UCRE766-SS71A

Model	Description	Voltage/Hz/Amps	Shipping Weight
UCRE733-SS31A	Roll-thru Refrigerator with Single Solid Door	115v / 60hz / 9.6	463 lb
UCRE766-SS71A	Roll-thru Refrigerator with Double Solid Door	115v / 60hz / 19.2	683 lb

Specifications

UCRE733-SS31A dimensions: 88 1/2" H x 33 7/8" W x 53 5/8" D
UCRE766-SS71A dimensions: 88 1/2" H x 66 7/8" W x 53 5/8" D
UCRE733-SS31A: Environmentally friendly R290 refrigerant - 3.5 oz
UCRE766-SS71A: Environmentally friendly R290 refrigerant - 7.0 oz
UCRE733-SS31A: Factory pre-wired for dedicated outlet, 11 ft cord and plug included NEMA 5-15P
UCRE766-SS71A: Factory pre-wired for dedicated outlet, 11 ft cord and plug included NEMA 5-20P
UCRE733-SS31A volume: 35.8 cu ft
UCRE766-SS71A Volume: 79 cu ft
AISI 304 stainless steel interior and exterior with lock
Autodefrost
CFC-free high density polyurethane insulated cabinet
Electronic digital temperature control with alarms
Epoxy coated, sealed evaporator eliminates potential of corrosion
Fixed stainless steel loading ramp
High efficiency compressor, top mount
High efficiency evaporator coil & condenser
NSF/ANSI Standard 7 compliant
Temperature range: 28°F to 46°F

Front UCRE733 (Open)

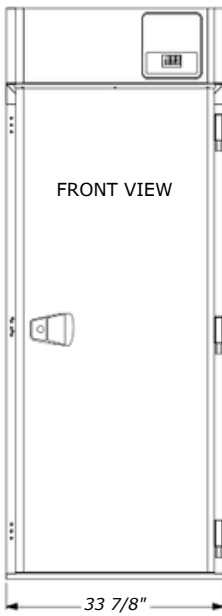

Front UCRE766 (Open)

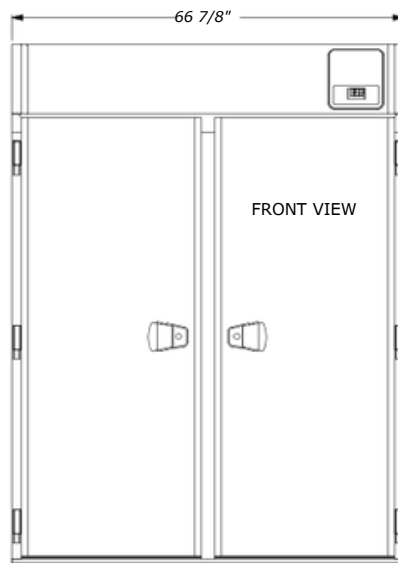

Side UCRE733/766

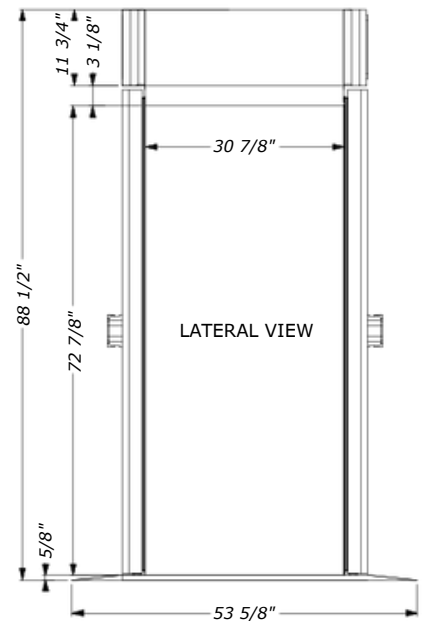

Top UCRE733

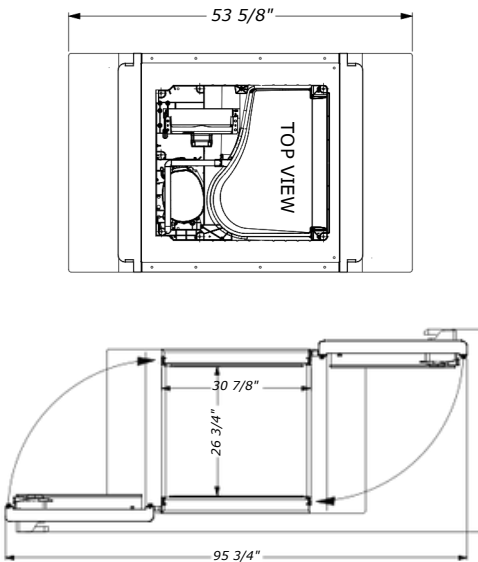

Top UCRE766

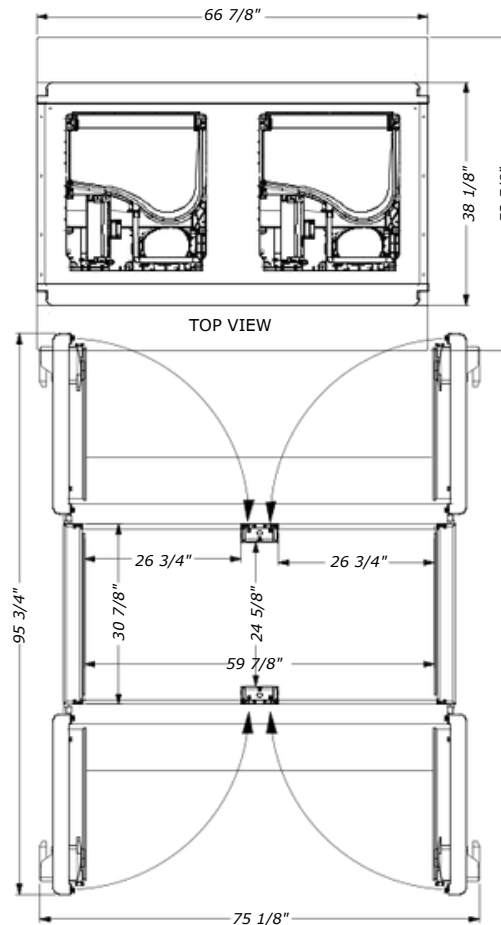

Back UCRE733/766

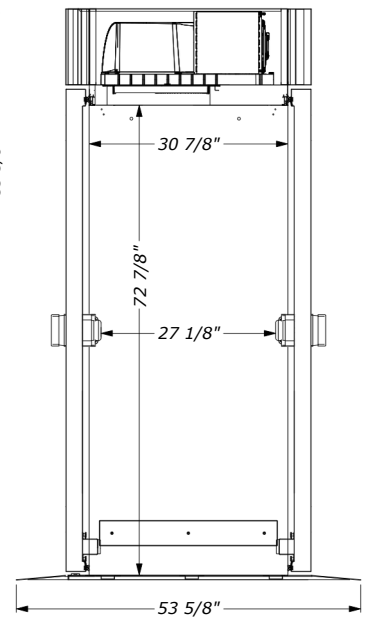

Commercial Warranty

3 Year (parts & labor) / 5 year sealed system (parts)
See complete warranty for details





Undercounter Front-Venting Refrigerators & Freezers

REFRIGERATION SOLUTIONS

Undercounter refrigerators and freezers are a staple in any kitchen setting. QualServ's front-venting design allows for easy installation under countertops, maximizing interior storage space in a small footprint, without compromising performance. Perfect for kitchens where space is limited, as undercounter appliances offer ideal integration without obstructing workflow or impeding access to other equipment. Our undercounter refrigerators and freezers offer versatile storage solutions, with adjustable shelving and spacious interiors capable of accommodating a variety of ingredients and perishables, from dairy products to fresh produce and beverages. Offered in a variety of sizes, these space-saving refrigerators and freezers compliment any space. Sturdy casters provide easy movement for an easy-to-clean environment and their sturdy construction and stainless steel components are built to withstand daily use. Delivering refrigeration and freezer storage, tailored to your operation.

Front-Venting Refrigerators

- Create a seamless, built-in look that adds a clean, professional appearance, ideal for open kitchens or customer-facing areas.
- Ensure efficient operation in high-traffic areas by directing heat away from the interior, maintaining consistent airflow even in compact spaces.
- Unidirectional casters included for easy maneuverability and stability in tight spaces.



UCRE327-SS11A



UCRE332-SS11A

Model	Description	Voltage/Hz/Phase/Amps	Shipping Weight
UCRE327-SS11A	27" Front-Venting 1 Door Refrigerator	115 / 60 / 1 / 3.4	221 lb
UCRE332-SS11A	32" Front-Venting 1 Door Refrigerator	115 / 60 / 1 / 3.4	242 lb

Specifications

UCRE327-SS11A dimensions: 33 31/32" H x 27 21/32" W x 31 3/4" D
UCRE332-SS11A dimensions: 33 31/32" H X 32 9/32" W X 31 13/16" D
UCRE327-SS11A: volume of 6.39 cu ft, 1 epoxy coated shelf
UCRE332-SS11A: volume of 8 cu ft, 1 epoxy coated shelf
AISI 304 stainless steel interior and exterior
Autodefrost
CFC-free high density polyurethane insulated cabinet
Electronic Control
Environmentally friendly R290 refrigerant
Epoxy coated, sealed evaporator eliminates potential corrosion
Factory pre-wired for dedicated outlet, 11 ft cord and plug included NEMA 5-15P
NSF/ANSI Standard 7 compliant
Temperature range: 28°F to 46°F

Front (UCRE327-SS11A)

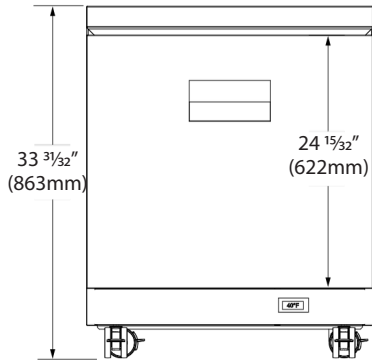

Top

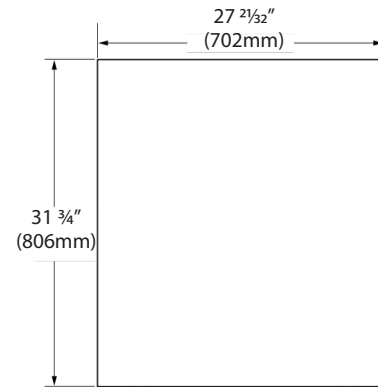

Front (UCRE332-SS11A)

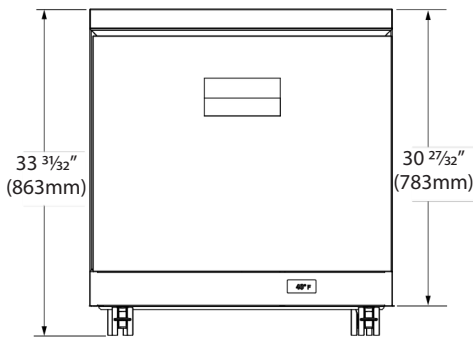

Top

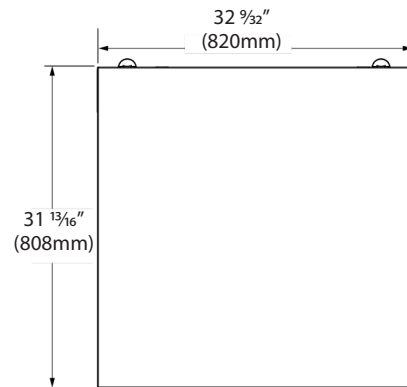

Side (all models)

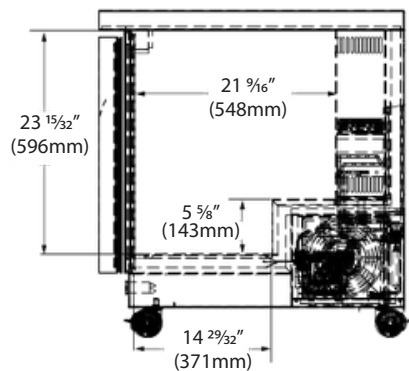

Commercial Warranty

3 Year (parts & labor) / 5 year sealed system (parts)
See complete warranty for details

Front-Venting Refrigerators

- Create a seamless, built-in look that adds a clean, professional appearance, ideal for open kitchens or customer-facing areas.
- Ensure efficient operation in high-traffic areas by directing heat away from the interior, maintaining consistent airflow even in compact spaces.
- Unidirectional casters included for easy maneuverability and stability in tight spaces.



UCRE336-SS61A



UCRE348-SS61A



UCRE360-SS61A



UCRE372-SS61A

Model	Description	Voltage/Hz/Phase/Amps	Shipping Weight
UCRE336-SS61A	2 Door Front-Venting Refrigerator	115 / 60 / 1 / 3.4	264 lb
UCRE348-SS61A	2 Door Front-Venting Refrigerator	115 / 60 / 1 / 3.4	286 lb
UCRE360-SS61A	2 Door Front-Venting Refrigerator	115 / 60 / 1 / 3.4	342 lb
UCRE372-SS61A	3 Door Front-Venting Refrigerator	115 / 60 / 1 / 6.8	430 lb

Specifications

UCRE336-SS61A dimensions: 33 31/32" H x 36 5/22" W x 31 13/16" D

UCRE348-SS61A dimensions: 33 31/32" H X 48" W X 31 3/4" D

UCRE360-SS61A dimensions: 33 31/32" H X 60 13/32" W X 31 3/4" D

UCRE372-SS61A dimensions: 33 31/32" H X 71 29/32" W X 31 3/4" D

UCRE336-SS61A: volume of 9.29 cu ft, 2 epoxy coated shelves

UCRE348-SS61A: volume of 13.17 cu ft, 2 epoxy coated shelves

UCRE360-SS61A: volume of 17.04 cu ft, 2 epoxy coated shelves

UCRE372-SS61A: volume of 19.86 cu ft, 3 epoxy coated shelves

AISI 304 stainless steel interior and exterior

Autodefrost

CFC-free high density polyurethane insulated cabinet

Electronic Control

Environmentally friendly R290 refrigerant

Epoxy coated, sealed evaporator eliminates potential corrosion

Factory pre-wired for dedicated outlet, 11 ft cord and plug included NEMA 5-15P

NSF/ANSI Standard 7 compliant

Temperature range: 28°F to 46°F

Top (UCRE336)

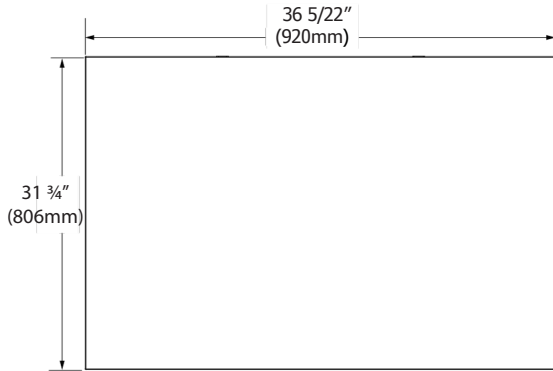

Top (UCRE348)

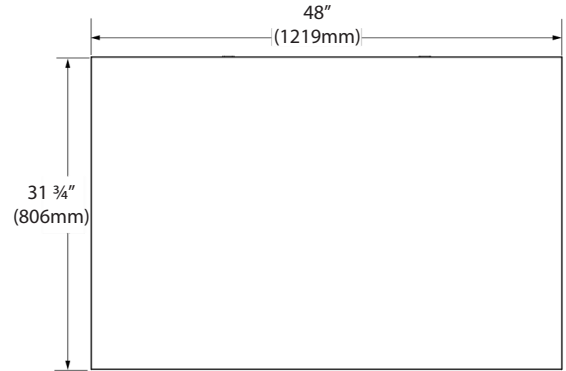

Top (UCRE372)

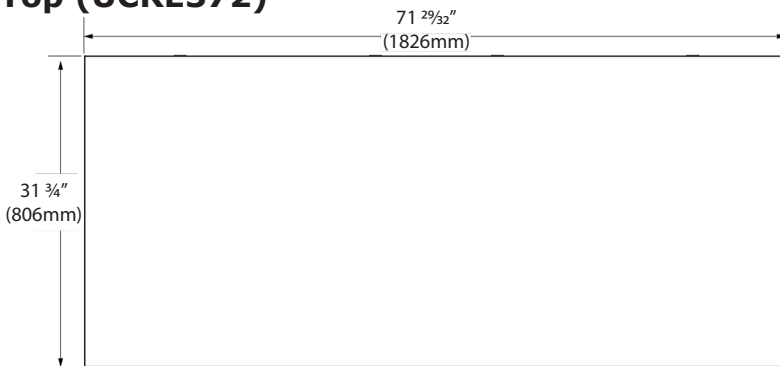

Top (UCRE360)

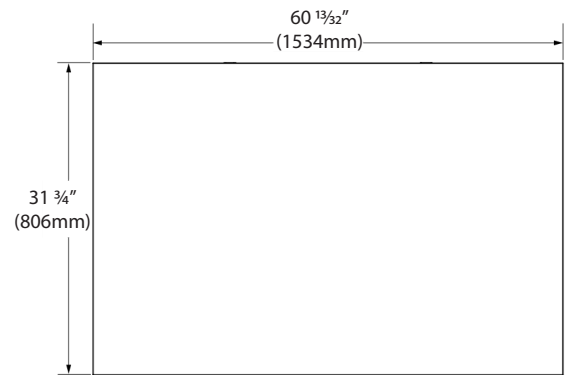

Front (UCRE336, 348, 360)

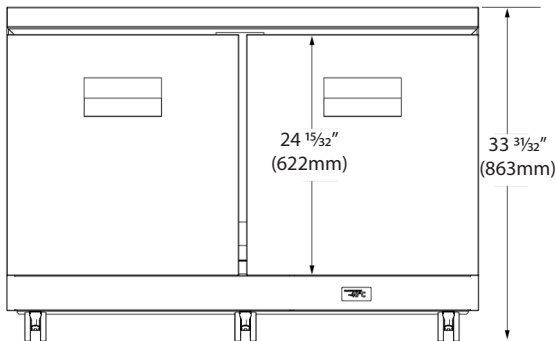

Side (all models)

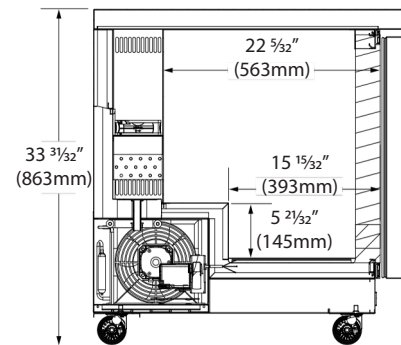

Front (UCRE372)

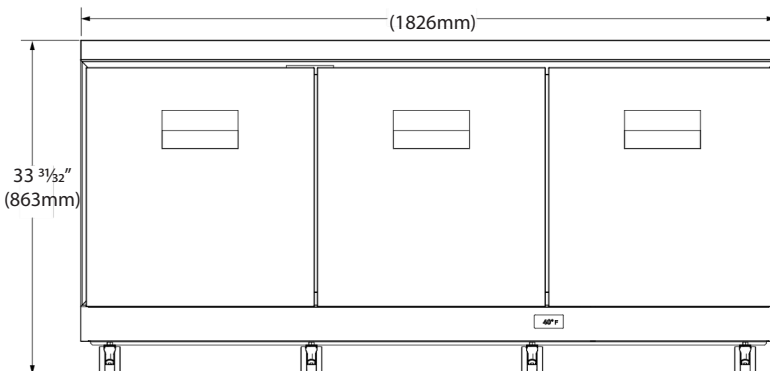

Commercial Warranty

3 Year (parts & labor) / 5 year sealed system (parts)
See complete warranty for details

Front-Venting Freezers

- Create a seamless, built-in look that adds a clean, professional appearance, ideal for open kitchens or customer-facing areas.
- Ensure efficient operation in high-traffic areas by directing heat away from the interior, maintaining consistent airflow even in compact spaces.
- Unidirectional casters included for easy maneuverability and stability in tight spaces.



UCFZ327-SS11A



UCFZ332-SS11A

Model	Description	Voltage/Hz/Phase/Amps	Shipping Weight
UCFZ327-SS11A	27" Front-Venting 1 Door Freezer	115 / 60 / 1 / 6	231 lb
UCFZ332-SS11A	32" Front-Venting 1 Door Freezer	115 / 60 / 1 / 6	253 lb

Specifications

UCFZ327-SS11A dimensions: 33 31/32" H x 27 21/32" W x 31 3/4" D
UCFZ332-SS11A dimensions: 33 31/32" H X 32 9/32" W X 31 13/16" D
UCFZ327-SS11A: volume of 6.39 cu ft, 1 epoxy coated shelf
UCFZ332-SS11A: volume of 8 cu ft, 1 epoxy coated shelf
AISI 304 stainless steel interior and exterior
Autodefrost
CFC-free high density polyurethane insulated cabinet
Electronic Control
Environmentally friendly R290 refrigerant
Epoxy coated, sealed evaporator eliminates potential corrosion
Factory pre-wired for dedicated outlet, 11 ft cord and plug included NEMA 5-15P
NSF/ANSI Standard 7 compliant
Temperature range: -13°F to 14°F

Front (UCFZ327-SS11A)

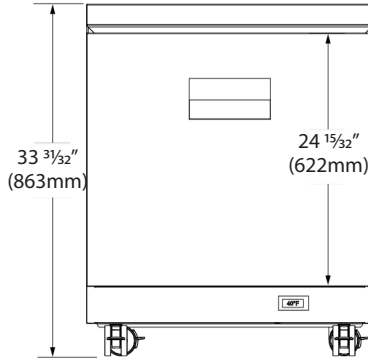

Top

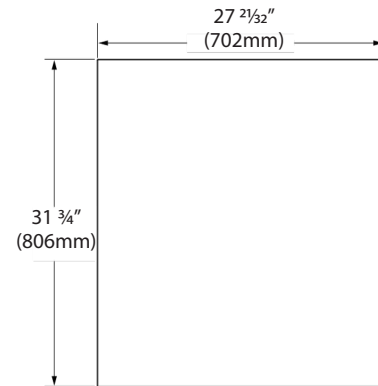

Front (UCFZ332-SS11A)

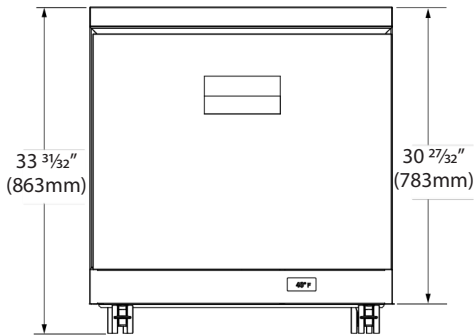

Top

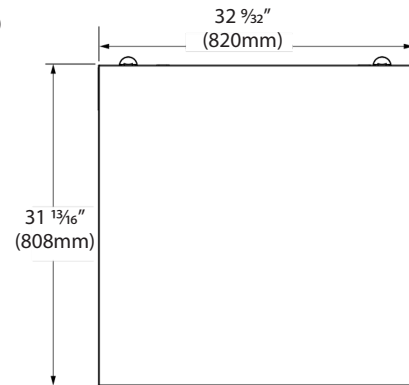

Side (all models)

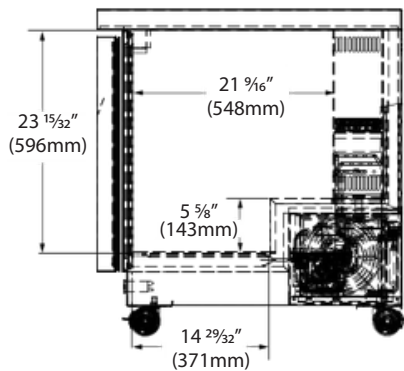

Commercial Warranty

3 Year (parts & labor) / 5 year sealed system (parts)
See complete warranty for details

Front-Venting Freezers

- Create a seamless, built-in look that adds a clean, professional appearance, ideal for open kitchens or customer-facing areas.
- Ensure efficient operation in high-traffic areas by directing heat away from the interior, maintaining consistent airflow even in compact spaces.
- Unidirectional casters included for easy maneuverability and stability in tight spaces.



UCFZ336-SS61A



UCFZ348-SS61A



UCFZ360-SS61A



UCFZ372-SS61A

Model	Description	Voltage/Hz/Phase/Amps	Shipping Weight
UCFZ336-SS61A	2 Door Front-Venting Freezer	115 / 60 / 1 / 6	264 lb
UCFZ348-SS61A	2 Door Front-Venting Freezer	115 / 60 / 1 / 6	319 lb
UCFZ360-SS61A	2 Door Front-Venting Freezer	115 / 60 / 1 / 6	342 lb
UCFZ372-SS61A	3 Door Front-Venting Freezer	115 / 60 / 1 / 12	452 lb

Specifications

UCFZ336-SS61A dimensions: 33 31/32" H x 36 5/22" W x 31 13/16" D

UCFZ348-SS61A dimensions: 33 31/32" H X 48" W X 31 3/4" D

UCFZ360-SS61A dimensions: 33 31/32" H X 60 13/32" W X 31 3/4" D

UCFZ372-SS61A dimensions: 33 31/32" H X 71 29/32" W X 31 3/4" D

UCFZ336-SS61A: volume of 9.29 cu ft, 2 epoxy coated shelves

UCFZ348-SS61A: volume of 13.17 cu ft, 2 epoxy coated shelves

UCFZ360-SS61A: volume of 17.04 cu ft, 2 epoxy coated shelves

UCFZ372-SS61A: volume of 19.86 cu ft, 3 epoxy coated shelves

AISI 304 stainless steel interior and exterior

Autodefrost

CFC-free high density polyurethane insulated cabinet

Electronic Control

Environmentally friendly R290 refrigerant

Epoxy coated, sealed evaporator eliminates potential corrosion

Factory pre-wired for dedicated outlet, 11 ft cord and plug included NEMA 5-15P

NSF/ANSI Standard 7 compliant

Temperature range: -13°F to 14°F

Top (UCFZ336)

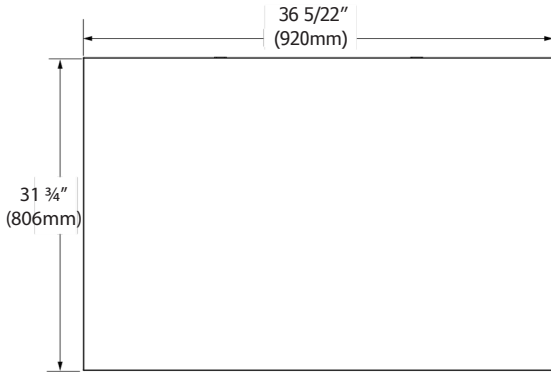

Top (UCFZ348)

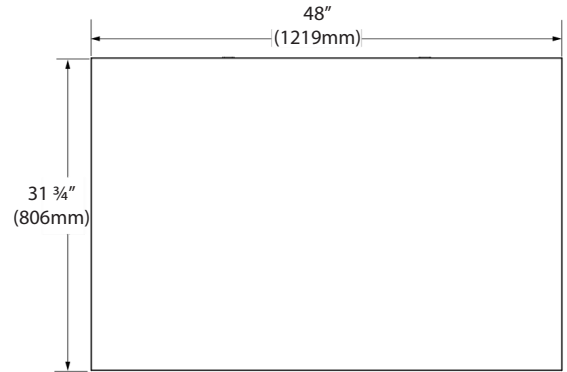

Top (UCFZ372)

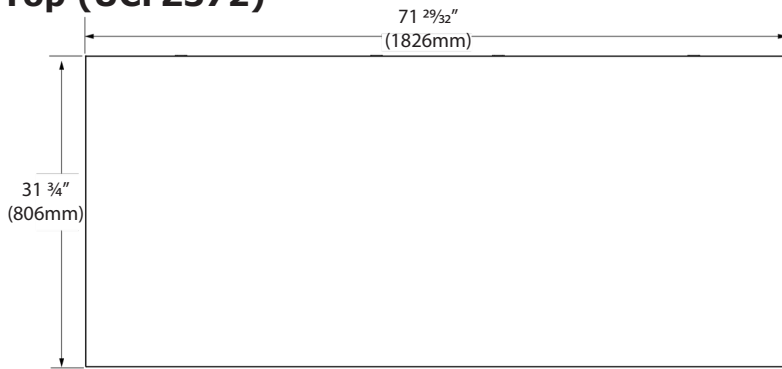

Top (UCFZ360)

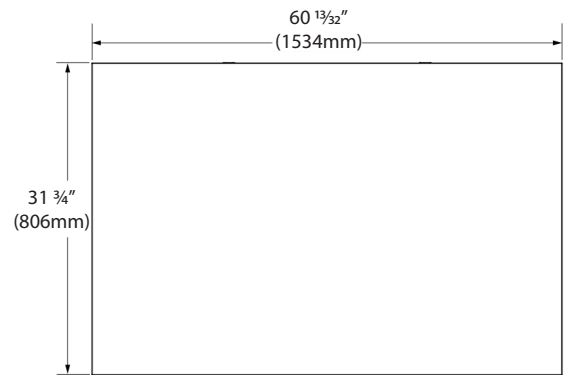

Front (UCFZ336, 348, 360)

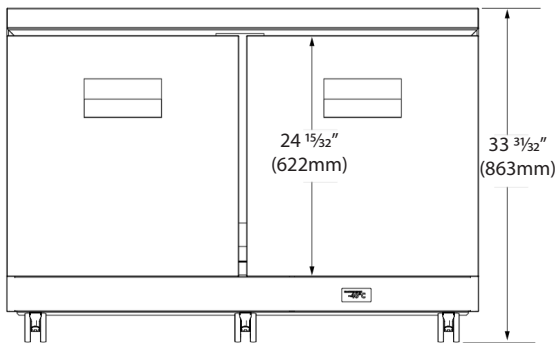

Side (all models)

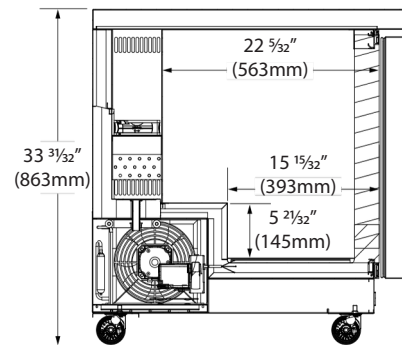

Front (UCFZ372)

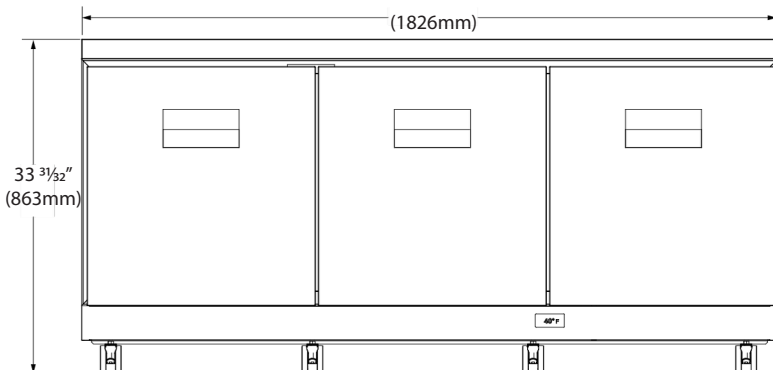

Commercial Warranty

3 Year (parts & labor) / 5 year sealed system (parts)
See complete warranty for details



Undercounter Side-Mount Refrigerators & Freezers

REFRIGERATION SOLUTIONS

From prep spaces to serving areas, undercounter refrigerators and freezers in today's kitchens allow chefs to maximize cold storage space. QualServ's side-mount undercounter refrigerators and freezers offer versatile storage solutions, with adjustable shelving and spacious interiors perfect for ingredients and prepared dishes. These units fit seamlessly under work surfaces, maximizing kitchen space, which is often at a premium, especially in commercial settings. Offered in 2, 3, and 4 door configurations, these products can be strategically placed around the kitchen and in service areas for specific needs. Casters create easy movement simple cleaning, and stainless steel components are built to withstand daily use. These reliable undercounter refrigeration and freezers deliver practical solutions fit for any kitchen.

Undercounter Refrigerators

- Casters included (2 locking) for easy mobility
- Convenient undercounter refrigeration designed to keep food fresh
- Available in a variety of sizes



Model	Description	Voltage/Hz/Phase/Amps	Shipping Weight
UCRE552-SS61A	2 Door Undercounter Refrigerator	115 / 60 / 1 / 5	353 lb
UCRE570-SS61A	3 Door Undercounter Refrigerator	115 / 60 / 1 / 5	507 lb
UCRE588-SS61A	4 Door Undercounter Refrigerator	115 / 60 / 1 / 5	551 lb

Specifications

UCRE552-SS61A dimensions: 35" H x 57 15/32" W x 27 9/16" D
UCRE570-SS61A dimensions: 35" H x 76 37/64" W x 27 9/16" D
UCRE588-SS61A dimensions: 35" H x 95 43/64" W x 27 9/16" D
UCRE552-SS61A: volume of 9.88 cu ft, 2 epoxy coated shelves
UCRE570-SS61A: volume of 15.57 cu ft, 3 epoxy coated shelves
UCRE588-SS61A: volume of 21.2 cu ft, 4 epoxy coated shelves
AISI 304 stainless steel interior and exterior
Autodefrost
CFC-free high density polyurethane insulated cabinet
Electronic Control
Environmentally friendly R449a refrigerant: UCRE552-SS61A: 41.1 oz (0.400 kg) / UCRE570-SS61A: 17.5 oz (0.500 kg) / UCRE588-SS61A: 17.5 oz (0.500 kg)
Epoxy coated, sealed evaporator eliminates potential corrosion
Factory pre-wired for dedicated outlet, 11 ft cord and plug included NEMA 5-15P
Max weight per shelf: 66 lb
NSF/ANSI Standard 7 compliant
Temperature range: 28°F to 46°F

Front (UCRE552-SS61A)

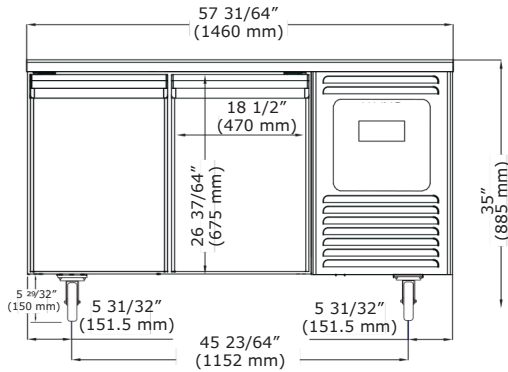

Top

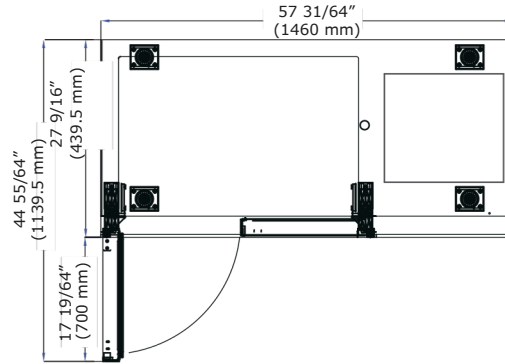

Front (UCRE570-SS61A)

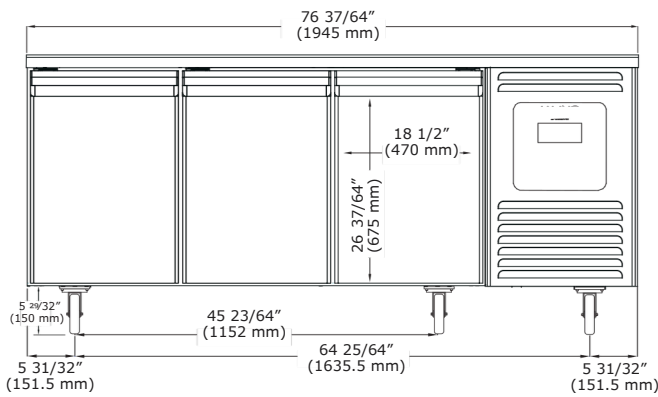

Top

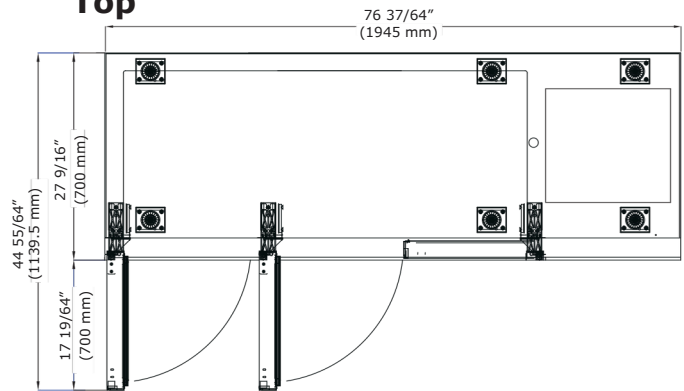

Front (UCRE588-SS61A)

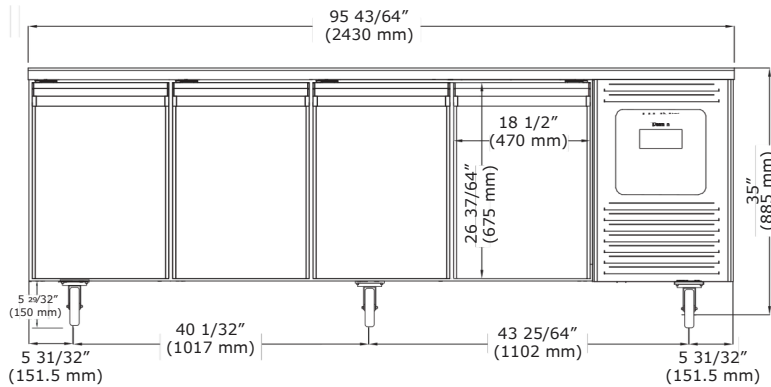

Side (all models)

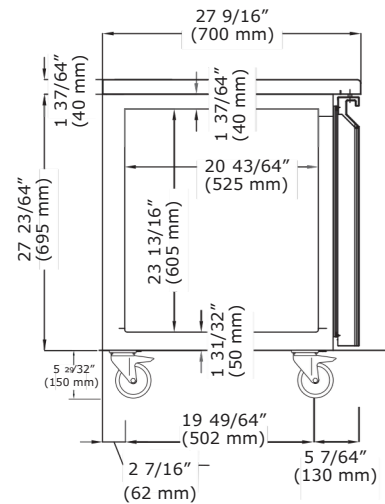

Top

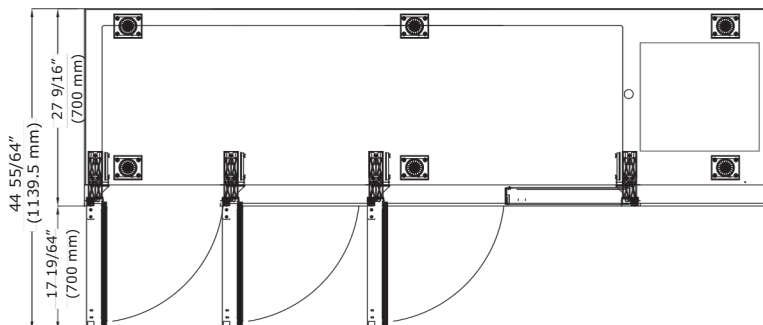

Commercial Warranty

3 Year (parts & labor) / 5 year sealed system (parts)
See complete warranty for details

Undercounter Freezers

- Convenient undercounter freezer storage designed to properly preserve food
- Confidently store ingredients and more where you need it most
- Available in a variety of sizes
- Casters available (2 locking) for easy mobility



Model	Description	Voltage/Hz/Phase/Amps	Shipping Weight
UCFZ552-SS61A	2 Door Undercounter Freezer	115 / 60 / 1 / 5	353 lb
UCFZ570-SS61A	3 Door Undercounter Freezer	115 / 60 / 1 / 5	507 lb
UCFZ588-SS61A	4 Door Undercounter Freezer	115 / 60 / 1 / 5	551 lb

Specifications

UCFZ552-SS61A dimensions: 35" H x 57 15/32" W x 27 9/16" D

UCFZ570-SS61A dimensions: 35" H x 76 37/64" W x 27 9/16" D

UCFZ588-SS61A dimensions: 35" H x 95 43/64" W x 27 9/16" D

UCFZ552-SS61A: volume of 9.88 cu ft, 2 epoxy coated shelves

UCFZ570-SS61A: volume of 15.57 cu ft, 3 epoxy coated shelves

UCFZ588-SS61A: volume of 21.2 cu ft, 4 epoxy coated shelves

AISI 304 stainless steel interior and exterior

Autodefrost

CFC-free high density polyurethane insulated cabinet

Electronic Control

Environmentally friendly R449a refrigerant: UCFZ552-SS61A: 8.1 oz (0.230 kg) / UCFZ570-SS61A: 14.1 oz (0.400 kg) / UCFZ588-SS61A: 14.1 oz (0.400 kg)

Epoxy coated, sealed evaporator eliminates potential corrosion

Factory pre-wired for dedicated outlet, 11 ft cord and plug included NEMA 5-15P

Max weight per shelf: 66 lb

NSF/ANSI Standard 7 compliant

Temperature range: -13°F to 14°F

Front (UCFZ552-SS61A)

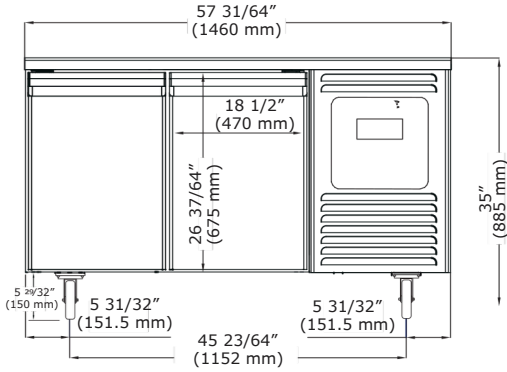

Top

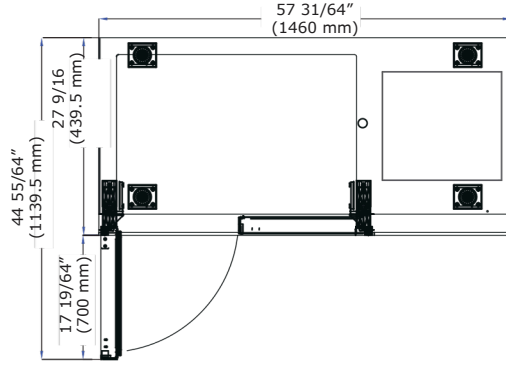

Front (UCFZ570-SS61A)

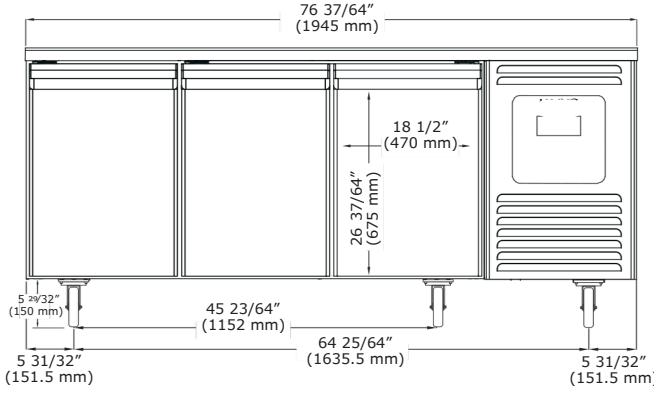

Top

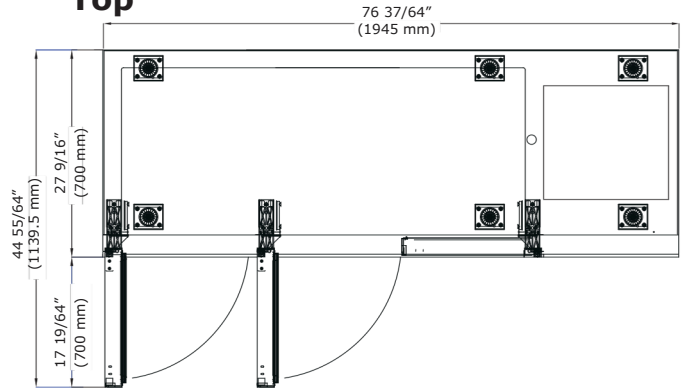

Front (UCFZ588-SS61A)

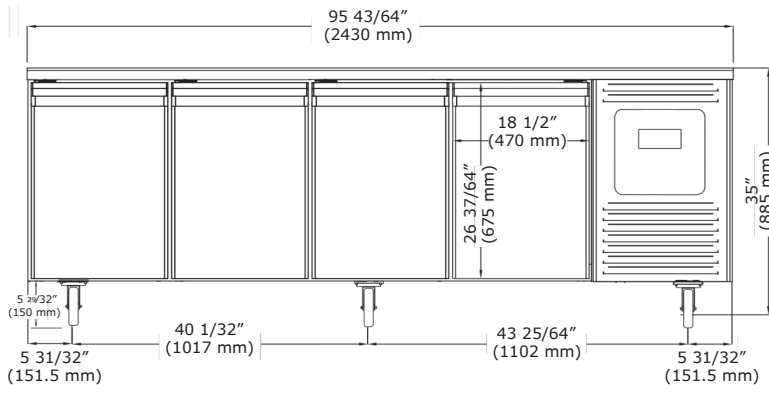

Side (all models)

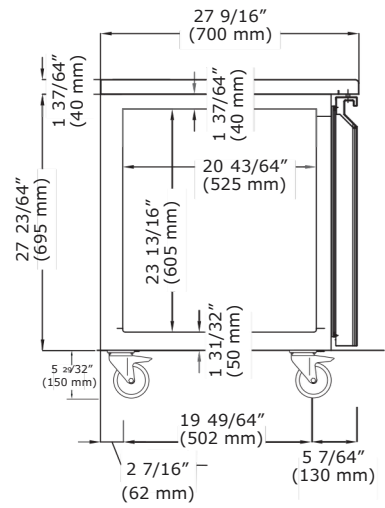

Top

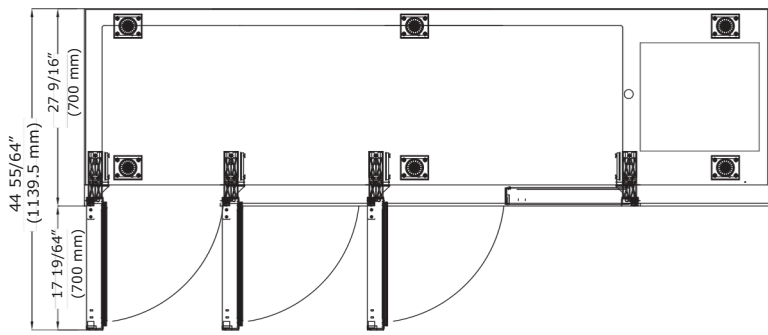

Commercial Warranty

3 Year (parts & labor) / 5 year sealed system (parts)
See complete warranty for details



Meat Curing Aging Cabinet

REFRIGERATION SOLUTIONS

Our versatile meat curing and aging cabinet is engineered to help operators consistently produce exceptional results—enhancing both flavor development and tenderness while maintaining tight control over food safety.

Built around precise temperature control, the cabinet creates a stable environment that supports reliable curing and aging outcomes from batch to batch. This controlled process helps meats develop deeper, more complex flavors and a more desirable texture, allowing you to confidently deliver a premium product and a consistent guest experience. To further protect product integrity, the cabinet integrates Brightshield antimicrobial lighting technology, which helps safeguard meat surfaces from harmful bacteria. This added layer of protection supports stronger food safety practices and can contribute to improved overall quality—especially important in high-value aging programs where consistency and risk reduction matter.

Designed for steakhouses, butcher shops, and gourmet kitchens, the cabinet supports a wide range of applications—from dry aging to curated curing programs—helping teams. Develop richer, more concentrated flavor profiles - Improve tenderness and texture through controlled aging - Reduce waste by protecting product quality and minimizing spoilage-related losses - Elevate menu differentiation with premium, house-aged offerings.

Meat Curing Aging Cabinet

- BrightShield® antimicrobial LED lighting maintains a hygienic environment, protecting meats from harmful bacteria.
- Spacious design allows for aging multiple cuts of meat simultaneously, enhancing efficiency.
- Includes 4 perforated metal shelves capable of holding up to 60 pounds of product.
- Comfortably fits 15 3/4" x 23 5/8" pans (not included).
- 4 casters (2 locking) included to provide easy mobility.



UCMA332-SG31A

Model	Description	Voltage/Hz/Phase/Amps.	Shipping Weight
UCMA332-SG31A	Meat Curing Aging Cabinet Glass Door, Field Reversible	220v / 60 Hz / 1ph / 6 A	243 lbs

Specifications
Dimensions: 80 1/4" H x 24 3/8" W x 31 1/2" D
AISI 304 stainless steel interior and exterior with lock
Autodefrost
CFC-free high density polyurethane insulated cabinet
Electronic digital temperature control with alarms
Environmentally friendly R290 refrigerant
Epoxy coated, sealed evaporator eliminates potential corrosion
Factory pre-wired for dedicated outlet, 11 ft cord and plug included NEMA 6-20P
High efficiency compressor, top mount
High efficiency evaporator coil & condenser
Includes 4 pairs of shelf supports
NSF/ANSI Standard 7 compliant
Temperature range: 37°F to 86°F
Volume of 16.7 cu ft.
Waterless system utilizes digital control to manage humidity

Front (Open)

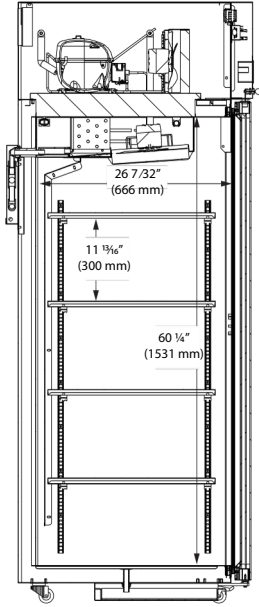

Front (Closed)

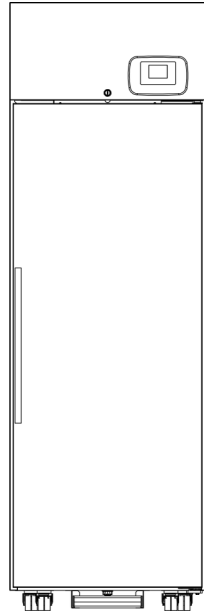

Side

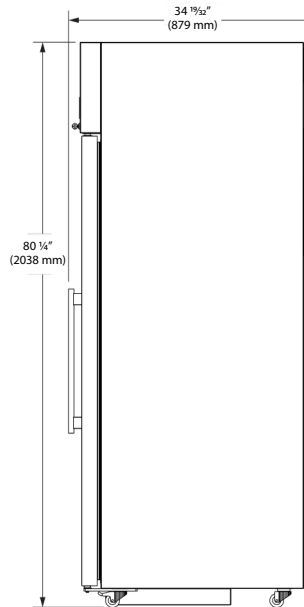

Back

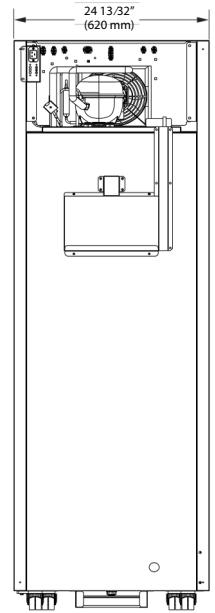

Top (Door Closed)

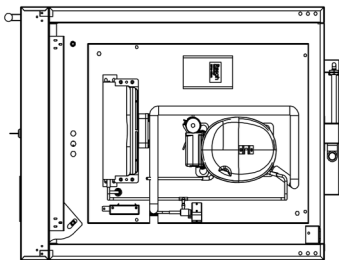

Top (Door Open)

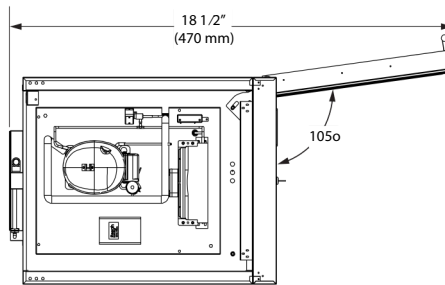

Top (Interior)

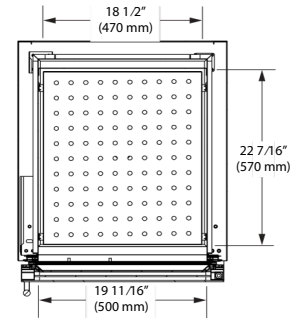

Commercial Warranty

3 Year (parts & labor) / 5 year sealed system (parts)
See complete warranty for details





Mobile Refrigerated Cabinet

REFRIGERATION SOLUTIONS

Our mobile refrigerator adds on-demand flexibility and efficiency to any commercial kitchen by combining reliable cold storage with easy maneuverability. Designed to move where you need it most, it helps teams optimize space, create extra refrigerated capacity, and keep perishable ingredients held at consistent, food-safe temperatures.

By positioning the unit closer to prep lines, garnish stations, or plating areas, operators can streamline workflow and reduce unnecessary trips to the main walk-in or reach-in. That means faster ticket times, less congestion in high-traffic zones, and a smoother, more organized kitchen during peak service. Ideal for busy production kitchens, catering operations, and special event or overflow spaces, this mobile solution is built with space efficiency, safety, and everyday convenience in mind—supporting better product access, improved organization, and more responsive kitchen setups as needs change throughout the day.

Mobile Refrigerated Cabinet

- Easily transport refrigeration with ergonomic handles, allowing for relocation within any commercial setting.
- 4 casters (2 locking) included to provide easy mobility.
- Vinyl bumper around the bottom for safety.



UCMR332-SS41A

Model	Description	Voltage/Hz/Phase	Shipping Weight
UCMR332-SS41A	Mobile Refrigerated Cabinet Solid Door, Right-Hand Hinge	220v / 60 Hz / 1ph	450 lbs

Specifications
Dimensions: 76" H x 31 1/2" W x 37 1/2" D
AISI 304 stainless steel interior and exterior with lock
Autodefroster
CFC-free high density polyurethane insulated cabinet
Environmentally friendly R452A refrigerant
Epoxy coated, sealed evaporator eliminates potential corrosion
Factory pre-wired for dedicated outlet, 11 ft cord and plug included NEMA 6-20P
High efficiency compressor, bottom mount
High efficiency evaporator coil & condenser
Includes 12 sets of pan slides
NSF/ANSI Standard 7 compliant
Temperature range: 34°F to 46°F
Toggle style on/off switch with guard
Volume of 11.65 cu ft.

Front (Open)

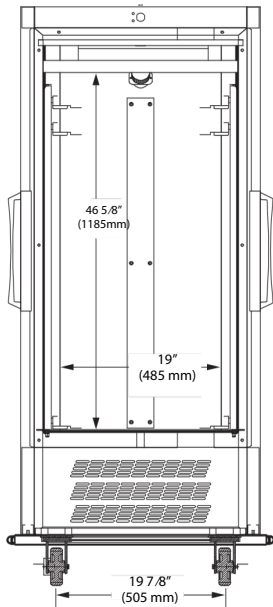

Front (Closed)

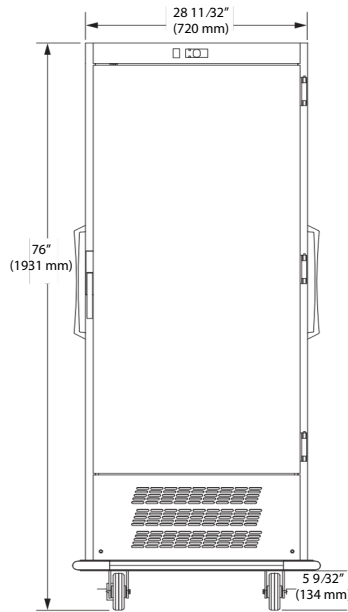

Back

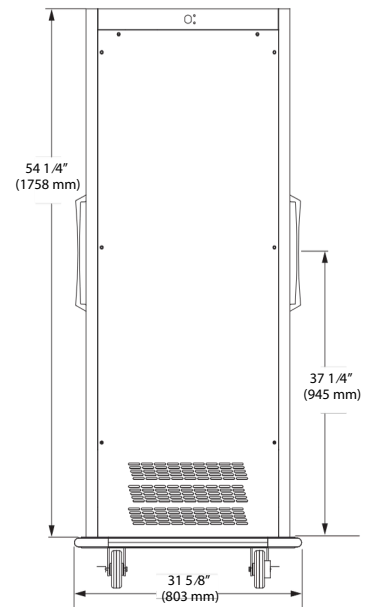

Side

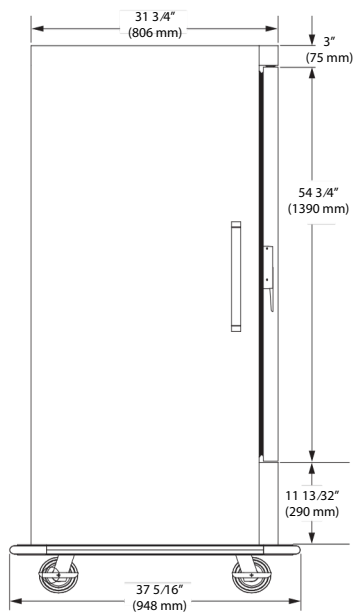

Side (Interior)

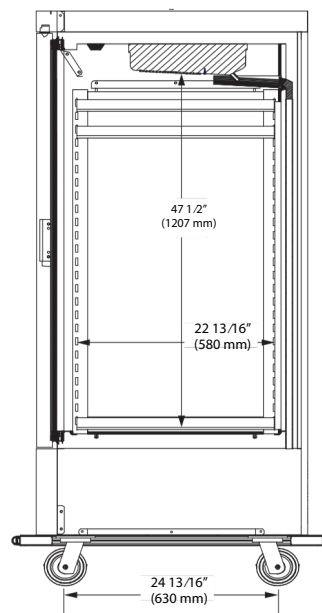

Commercial Warranty

3 Year (parts & labor) / 5 year sealed system (parts)
See complete warranty for details





Proofer Retarder Combination, Reach-In

REFRIGERATION SOLUTIONS

The QualServ Commercial reach-in proofer retarder combines the dual functions of proofing and retarding (controlled fermentation) in one space-saving footprint—helping kitchens and bakeries produce consistent dough results while maximizing valuable floor space.

With precise temperature and humidity control, the unit creates a stable environment that supports predictable yeast activity and moisture retention. This consistency helps dough rise evenly, improving volume, texture, and finished product quality while reducing variability from batch to batch.

Ideal for bakeries, restaurants, cafés, hotels, and pizzerias, this versatile unit supports a wide range of dough-based products—from breads and rolls to pizza dough and pastries—enhancing back-of-house efficiency and helping ensure your creations proof and ferment to perfection, every time.

Proofer Retarder Combination, Reach-In

- With both retarding and proofing capabilities, optimize space and enhance efficiency in commercial baking operations.
- Comfortably fits 15 3/4" x 23 5/8" pans (not included).
- 4 casters (2 locking) included to provide easy mobility.
- LED interior lighting.
- Utilizes up to 4 different recipe settings.



UCPR322-SG41A

Model	Description	Voltage/Hz/Phase	Shipping Weight
UCPR322-SG41A	Proofer Retarder Combination Glass Door, Right-Hand Hinge	220v / 60 Hz / 1ph	243 lbs

Specifications

Dimensions: 83 1/2" H x 24 3/8" W x 31 1/2" D
AISI 304 stainless steel interior and exterior with lock
Autodefrost
CFC-free high density polyurethane insulated cabinet
Electronic digital temperature control with alarms accurately tracks temperature, humidity & time
Environmentally friendly R290 refrigerant
Epoxy coated, sealed evaporator eliminates potential corrosion
Factory pre-wired for dedicated outlet, 11 ft cord and plug included NEMA 6-20P
High efficiency compressor, top mount
High efficiency evaporator coil & condenser
Includes 15 pairs of shelf guides
NSF/ANSI Standard 7 compliant
Temperature range: 16°F to 86°F
Volume of 16.6 cu ft.

Front

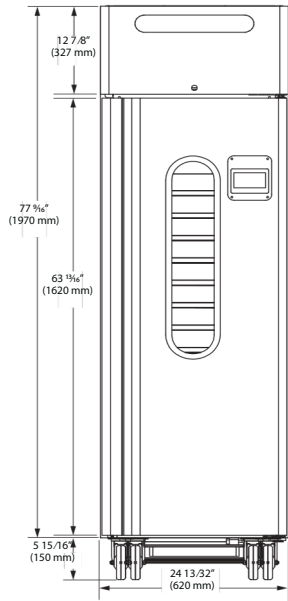

Side

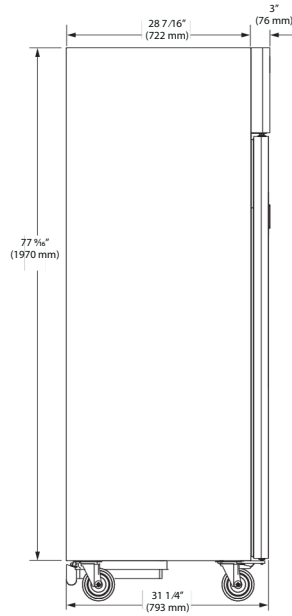

Top

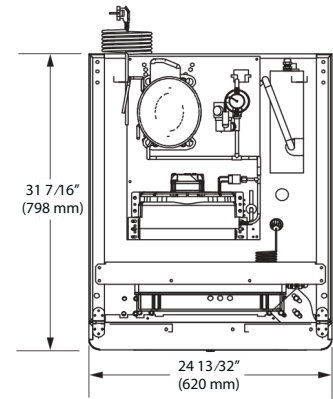

Water Connection

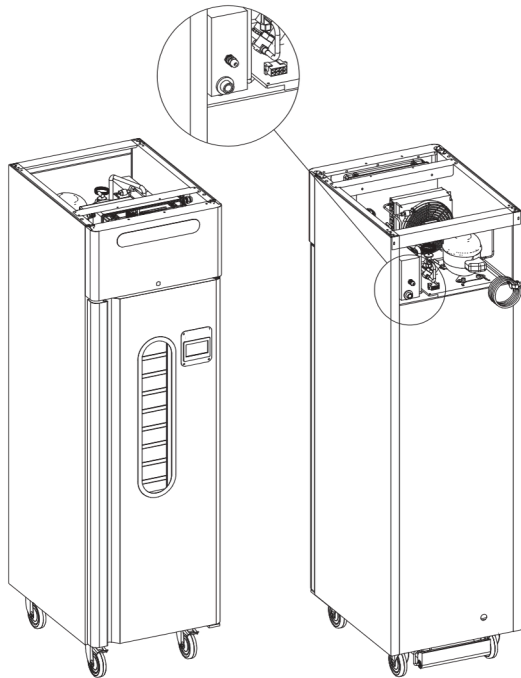

Commercial Warranty

3 Year (parts & labor) / 5 year sealed system (parts)
 See complete warranty for details



QS



QUALSERV[®]
SOLUTIONS INTERNATIONAL